

S35-T2 EVO

1/8 OffRoad Nitro Power Pro Truggy



S WORKZ S35-T2 EVO INSTRUCTION MANUAL

S35-T2EVO

1/8 OffRoad Nitro Power Pro Truggy

INSTRUCTION

Further continuing with the successful SWORKz S35-T2 1/8 Nitro Truggy platform, the latest S35-T2 EVO is designed for an even higher level of racing.

The new steering geometry from the S35-4 EVO kit provides optimized cornering speeds with a more easy handling feel and maximum traction.

The S35-T2 EVO features a T7075 hard anodized and lightened aluminum chassis with a new short wheel base design that was tested for a long time by our factory pilots which guarantee the best speed balance for both front and rear suspensions.

HET differentials are included in the kit while the High Density Clutch Bell system are optional.

The new S35-T2 EVO comes with a brand new steering Lay-Down Type Steering Bell crank servo savor system. This new Ackerman design provides the driver with better control over the S35-T2 EVO Truggy.

In the kit we also include special BBS pistons and oil seal parts that the worlds team drivers tested during the worlds. The parts are made by a high Precision Plastic mold machine.

Also included are specially made durable material parts for the suspension like inserts which our team drivers prefers and immediately felt more confident with them.

There are many more small changes and ideas in the new SWORKz S35-T2 EVO. It is an evolution step designed and tested by the whole team that make the car even better.

The secret of a modern racing car is the possibility to adapt the car setup to every track for top pilots but also have a standard setup that works on most tracks for hobby pilots. The SWORKz S35-T2 EVO fulfills these two characteristics.

S35-T2 EVO Kit Features:

- T7075 Hard Anodized, Lightened Aluminum Chassis
- S35 Series BBS System Hex-Cell Shock (New)
- SWORKz 1/8 BBS Precision Plastic Shock Piston (New)
- Fixed Shock Spring Holder
- 3mm Updated Rear Shock Studs
- Ackerman Plate (New)
- Steering System (New)
- Servo Saver Aluminium Part (New)
- Servo Saver Plate (New)
- Servo Saver Post Locking Design (New)
- Steering Ball Studs (New)
- Steering Knuckle Plates (New)
- Updated Toe In Plates with Square Inserts (New)
- Aluminum Intensity F/F and R/F Narrow Lower Suspension Plate
- New Carbon Center Diff Plate with Throttle Servo Linkage System (New)
- Nitro Series Center Brake Disk Holder (New)
- Lightweight Wing Mount
- Composite Rear Hubs with Carbon Plates
- Multi Adjustable Ball System for Rear Upper Arms
- Anticlock Screws for Shocks
- Aerodinamically Optimized Body Shell
- 3 HET Differentials Included
- 2 Front Chassis Braces Included
- Black Competition Shock Springs Included
- Adjustable Wing Position
- Adjustable Wing Angle
- More Balance Weight Positions
- Stronger Downstop Area
- Optimized Composite Material
- Aluminium Parts in T7075

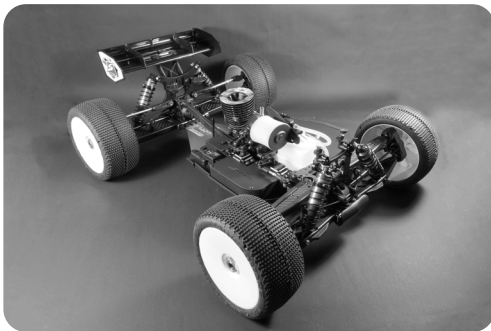

Specification	
Length:	560mm
Width:	410mm
Height:	230mm
Ground Clearance:	80mm
Wheelbase:	375-380mm
Track:	F:366mm /R:368mm
Gear Ratio:	C:48/13T, F/R:46/10T
Weight:	3980g (Race condition)

WARRANTY

Your SWORKz S35-T2 EVO kit warranty covers workmanship and manufacturing defects of the original and unmodified parts. Warranty claims resulting from crashes, abuse, improper operation, improper mounting, improper adjustment or lack of maintenance will not be honored.

Contact your local hobby shop or SWORKz distributor for all claims and questions. Claims must be well documented. All Claims are subject to expert examination approval by SWORKz.



INSTRUCTION	2
Warranty	3
INDEX	4
Required Equipment for Operation	5
Operation Guide	6
Assembly Steps	7-36
Blank Set-up sheet	37-38
Set-up Sheet	39
S35-T2 EVO Key No. List	40-41
S35-T2 EVO Spare Part List	41-42
S35-T2 EVO Option Part List	43
Explosion view with spare parts number	44-47
End cover	48



This radio controlled racing car is not a toy!

This high-performance R/C model is recommended for ages 14 and older.

Required Equipment for Operation

Radio Gear

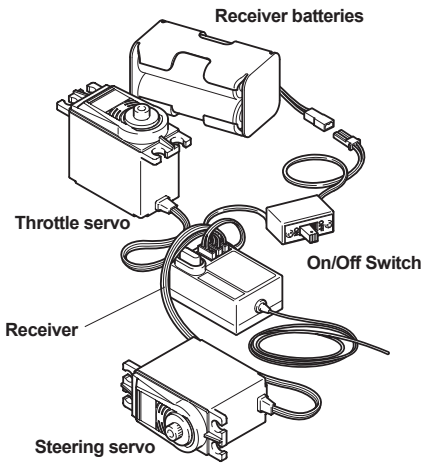
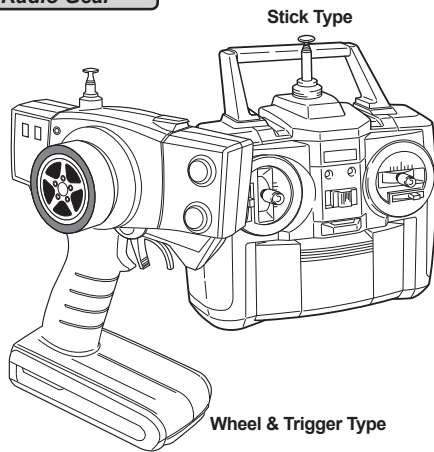

Nitro fuel

We recommend that you use fuel containing 20~25% nitro.



Engine Recommended



Spower Japan B7HP
SOUL Factory
Hand-Made Modified
.21 OffRoad Racing
Engine (Pre-Break-in)

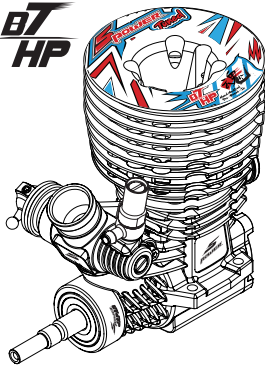

Exhaust header



SP-80109
Spower Japan
EFRA 2155 Tuned Pipe Set
(Made by O.S. Japan)

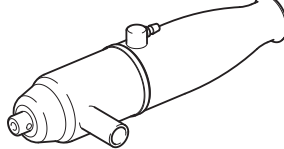

Engine Starting Equipment



ST-3 Turbo Plug
ST-4 Turbo Plug

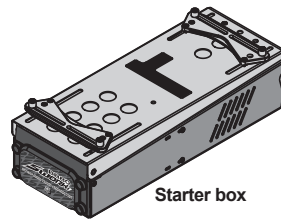

Starter box

Glow Plug



1/8 OFF ROAD STARTER BOX [EGGY TYPE]

Tools Recommended

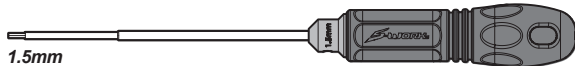

1.5mm

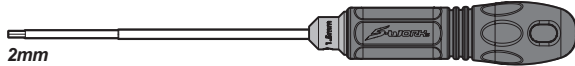

2mm

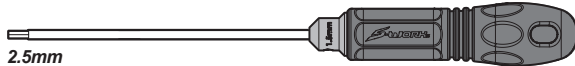

2.5mm

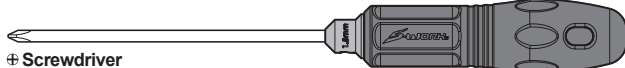

+ Screwdriver

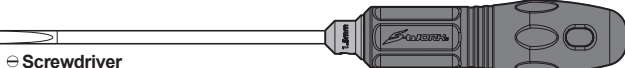

⊖ Screwdriver

Long nose pliers

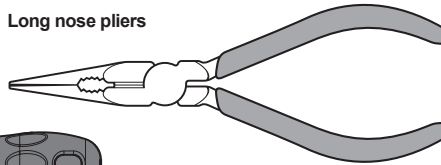

Side cutter

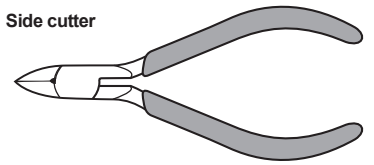

Curved scissors

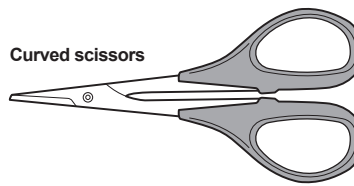

Paint



Modeling knife

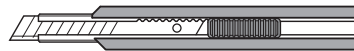

Instant cement

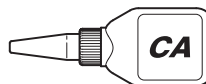

Thread lock

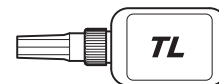

Double-sided tape



Included items

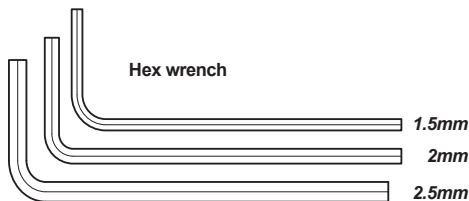

Hex wrench

1.5mm

2mm

2.5mm

Glow plug wrench

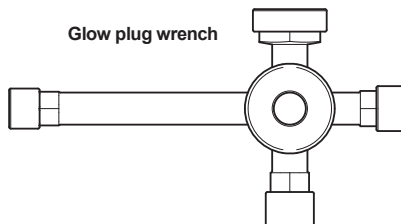

Grease

Operation Guide



Assemble front and rear

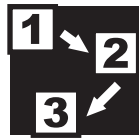

Assemble in the specified order



Assemble both left and right sides



Assemble for 2 sets



Assemble for 4 sets

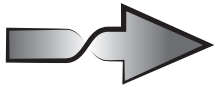

overturn



Thread Locking Compound



Grease

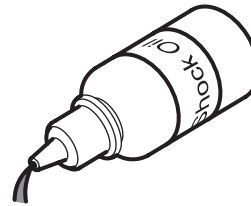

Pure Silicone Oil



Air filter oil

Safety Precautions

The SWORKz S35-T2 EVO is a high performance radio control model which needs to be operated with caution and common sense.

The S35-T2 EVO Kit is not intended for children under the age of 14 without adult supervision. SWORKz shall not be held liable for any loss or damages, whether direct, indirect, act of nature, arising from the abuse or misuse of this product or any other product required while operating this model.

- The nitro fuel can be dangerous is improperly handled.
- Always keep your nitro fuel in a cool area and never use near flame, sparks, or while smoking.
- Keep your nitro fuel, and all other flammables, out of the reach of children.
- Always run your model in a well ventilated area outdoors. Never run your model indoors.
- After running your car, all parts of the engine and exhaust can become extremely hot. Be careful not to touch these parts especially when refueling, or making repairs.
- This model is controlled by your radio controller and is sometimes vulnerable to interference from many outside sources. This interference can cause a loss of control so it is necessary to operate this model in an open area to avoid personal, or property damage. Always ensure turning on your radio first.
- Keep all the parts included in the package out of reach of children.
- This model contains many fast rotating parts. Never touch them during operation.
- Follow the instructions included with your radio gear.
- Never operate your model near people or property. The speed of this model has the potential to injure and or damage people and or property.
- Always use original SWORKz spare parts and option parts.
- Always ensure that the buggy is in proper working condition before use.

BAG B

1 **F** **R** **x2**

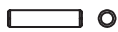

330015
Pin M2.2x9.9mm **x4**



400002
O-ring S5 4.8X1.5 **x4**



101039
Washer 5x12x0.3 **x2**



116006R
Ball Bearing 8x16x5mm (Red Rubber Case) **x4**

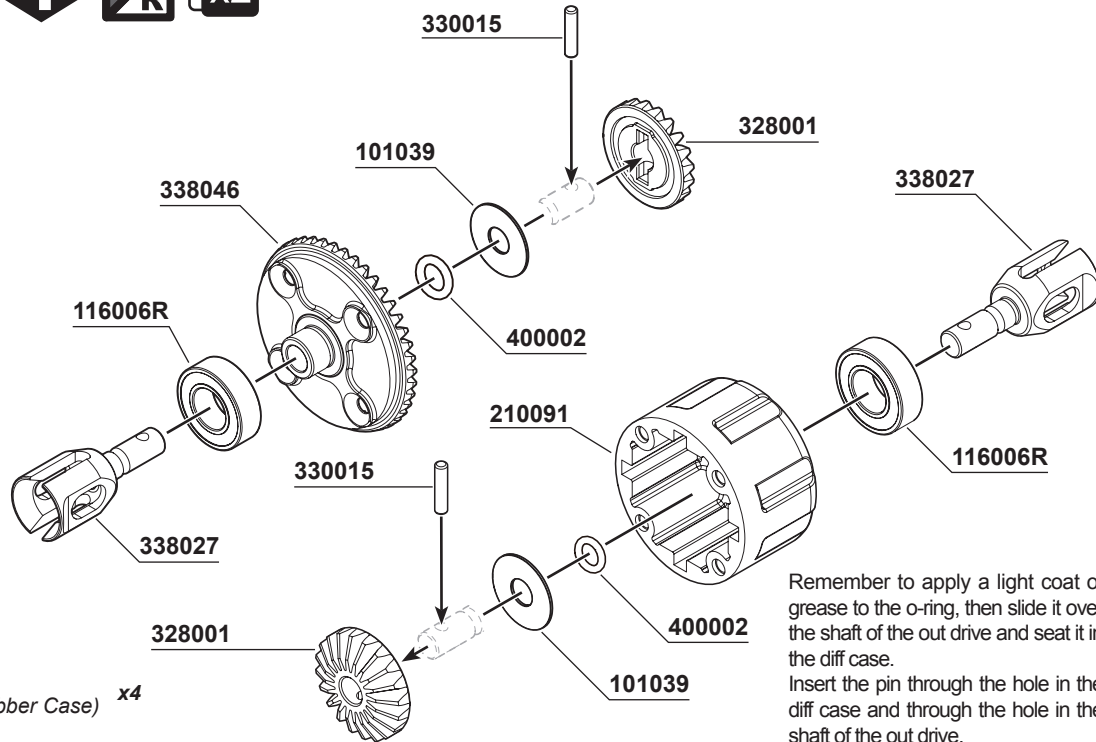

Remember to apply a light coat of grease to the o-ring, then slide it over the shaft of the out drive and seat it in the diff case.
Insert the pin through the hole in the diff case and through the hole in the shaft of the out drive.

2 **F** **R** **x2**



108003
M3x10mm FH/ST HEX Screw **x8**

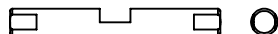

338025
S35-3W Bevel Gear Shaft **x4**

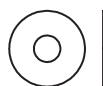

101004
Washer 3.5X10X0.2mm **x8**

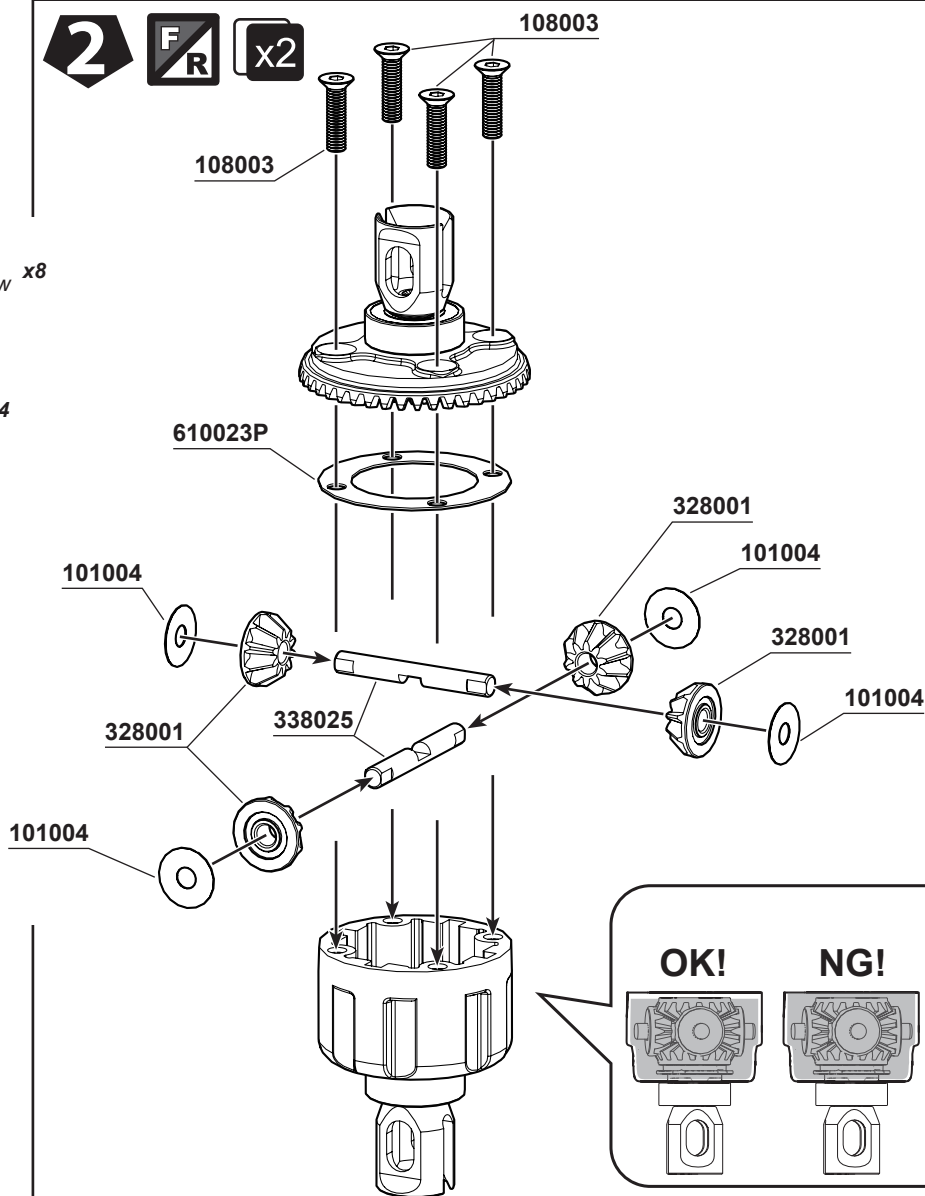

OK!

NG!

Fill the differentials with oil up to 80% above the satellite gears.
Put the SWORKz Diff. Oil 7000cps for the front Diff. and 3000cps for the rear Diff.

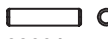
 **330015**
Pin M2.2x9.9mm x2

 **400002**
O-ring S5 4.8X1.5 x2

 **116006R**
Ball Bearing 8x16x5mm (Red Rubber Case) x2

 **101039**
Washer 5x12x0.3 x2

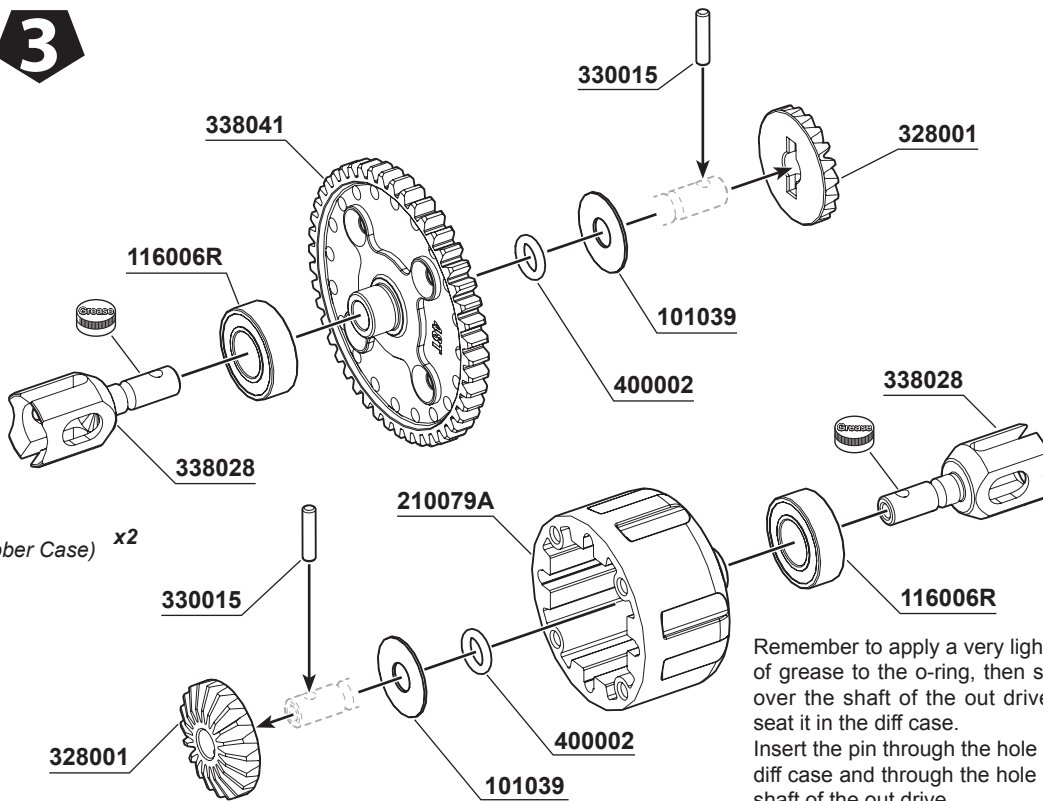

Remember to apply a very light coat of grease to the o-ring, then slide it over the shaft of the out drive and seat it in the diff case. Insert the pin through the hole in the diff case and through the hole in the shaft of the out drive.

 **108001**
M3x12mm FH/ST HEX Screw x4

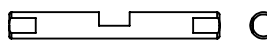
 **338025**
S35-3W Bevel Gear Shaft x4

 **101004**
Washer 3.5X10X0.2mm x4

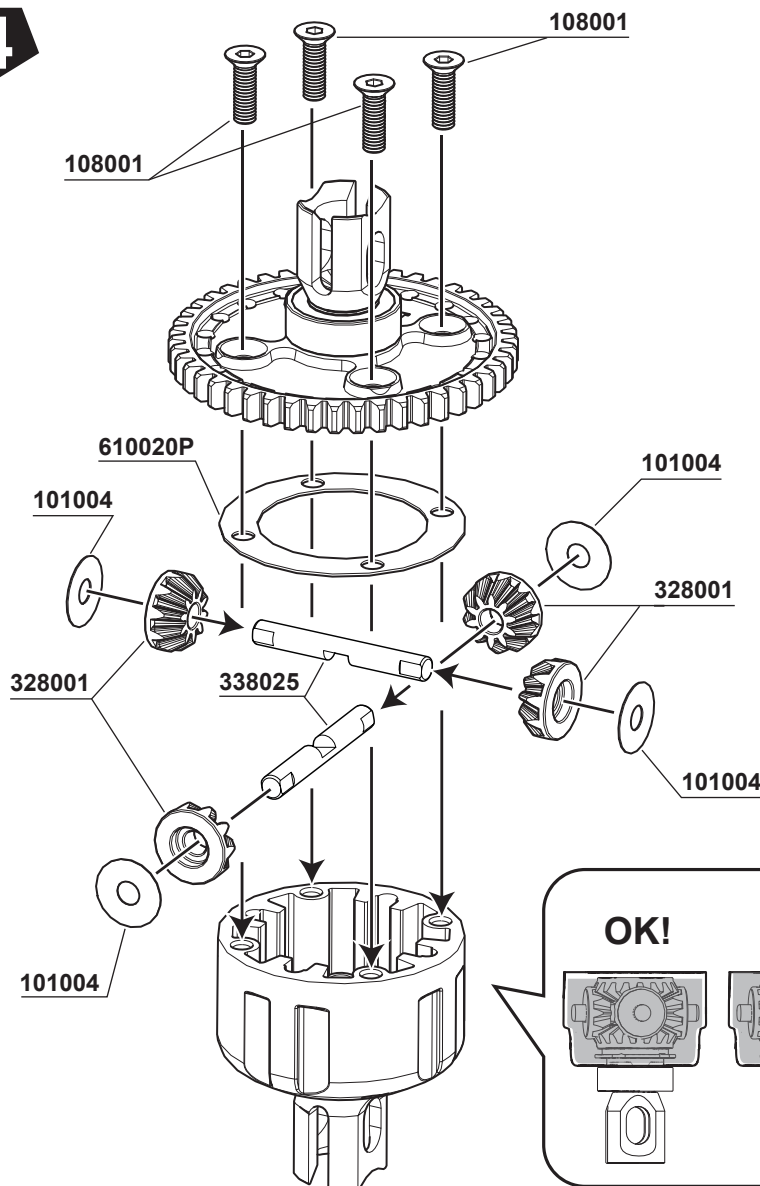

OK!

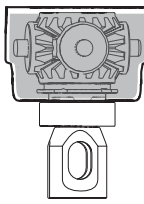

NG!

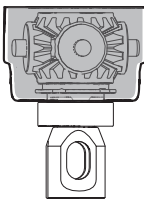

Fill the differentials with oil up to 80% above the satellite gears. Put the SWORKz Diff. Oil 7000cps for the center Diff.

Pro Tip:
Before installing the M5x4 set screw (104010), remember to clean the set screw and center driver joint (330661A) first. Then apply TLC on the set screw.

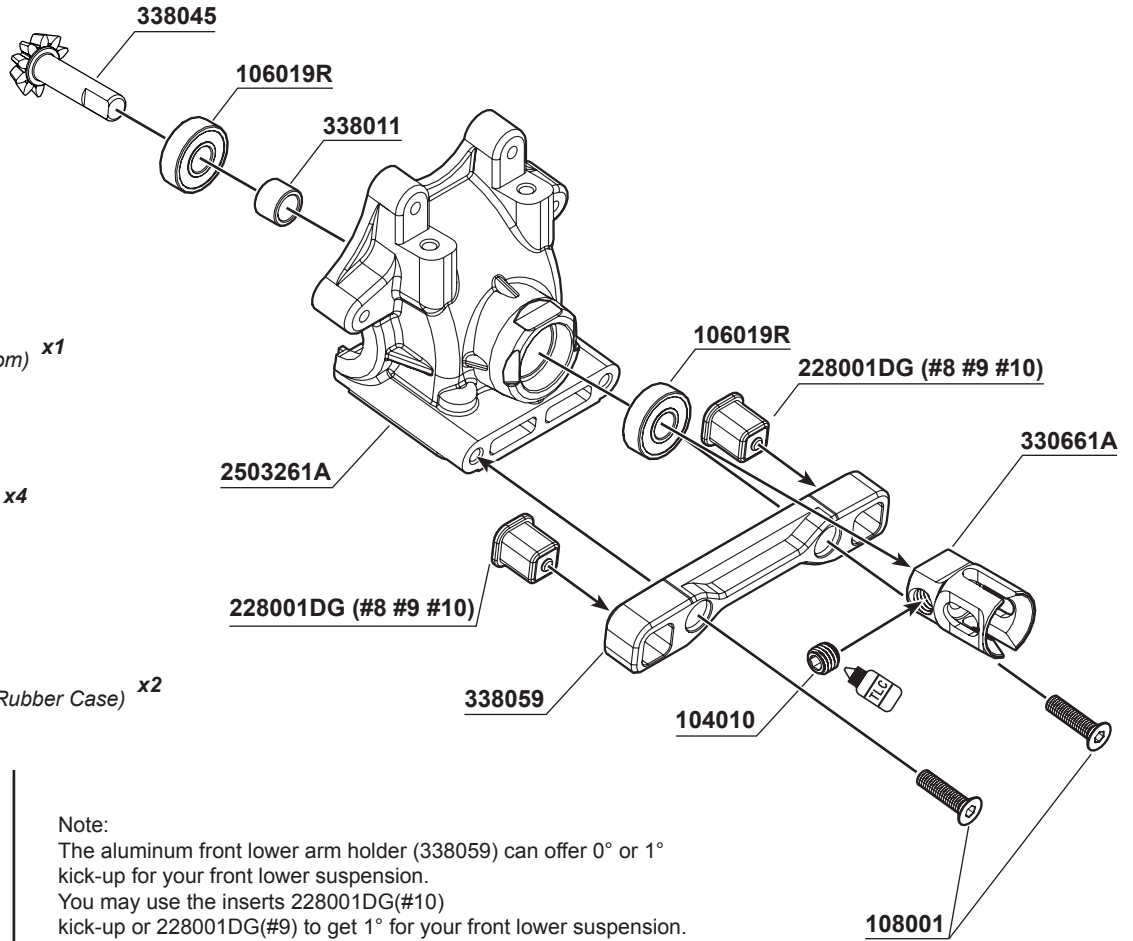

104010
M5x4mm Set Screw (Flat Bottom) **x1**



108001
M3x12mm FH/ST HEX Screw **x4**



116019R
Ball Bearing 5x13x4mm (Red Rubber Case) **x2**

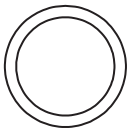

101018
SHIM 13x16x0.2mm **x4**



338011
S35 series Pinion Gear Stopper (5x7x5.1mm) **x1**

Note:
The aluminum front lower arm holder (338059) can offer 0° or 1° kick-up for your front lower suspension. You may use the inserts 228001DG(#10) kick-up or 228001DG(#9) to get 1° for your front lower suspension.

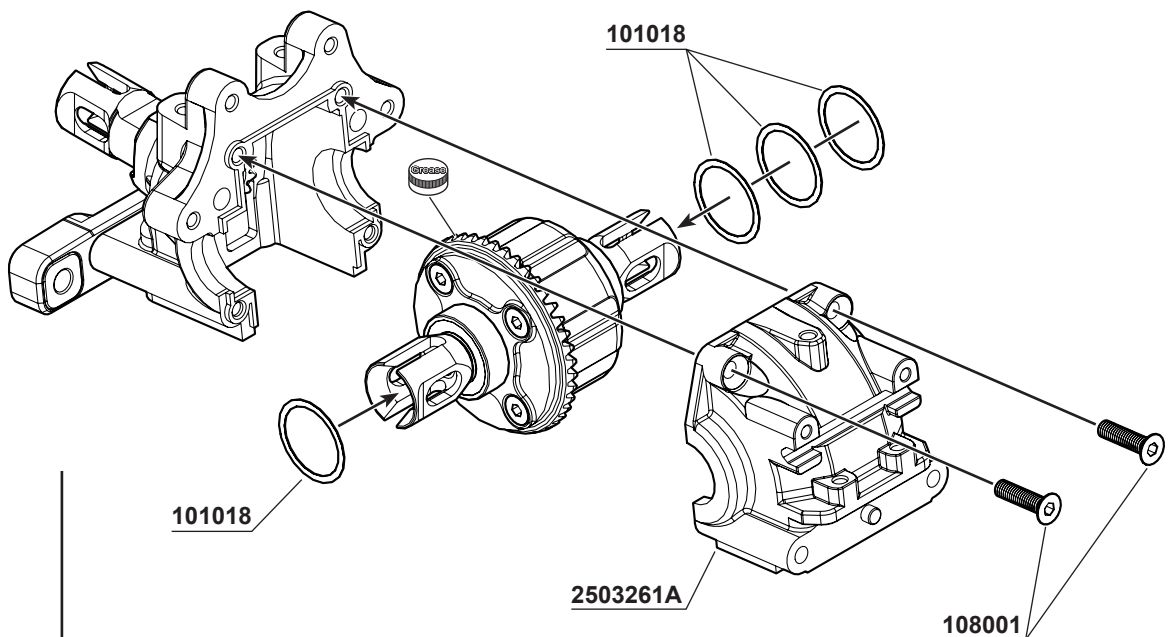

Note:
101018SHIM 13x16x0.2mm
Please use 13x16x0.2mm shims to adjust the play between the crown gear and pinion gear. Standard suggestion is 1pc shim on the diff crown gear side and 3 pcs on the other side.

BAG D

6 Rear

Pro Tip:
Before installing the M5x4 set screw (104010), remember to clean the set screw and center driver joint (330661A) first. Then apply TLC on the set screw.

108001
M3x12mm FH/ST HEX Screw x2

108005
M3x14mm FH/ST HEX Screw x2

104010
M5x4mm Set Screw (Flat Bottom) x1

116019R
Ball Bearing 5x13x4mm (Red Rubber Case) x2

101018
SHIM 13x16x0.2mm x4

338011
S35 series Pinion Gear Stopper (5x7x5.1mm) x1

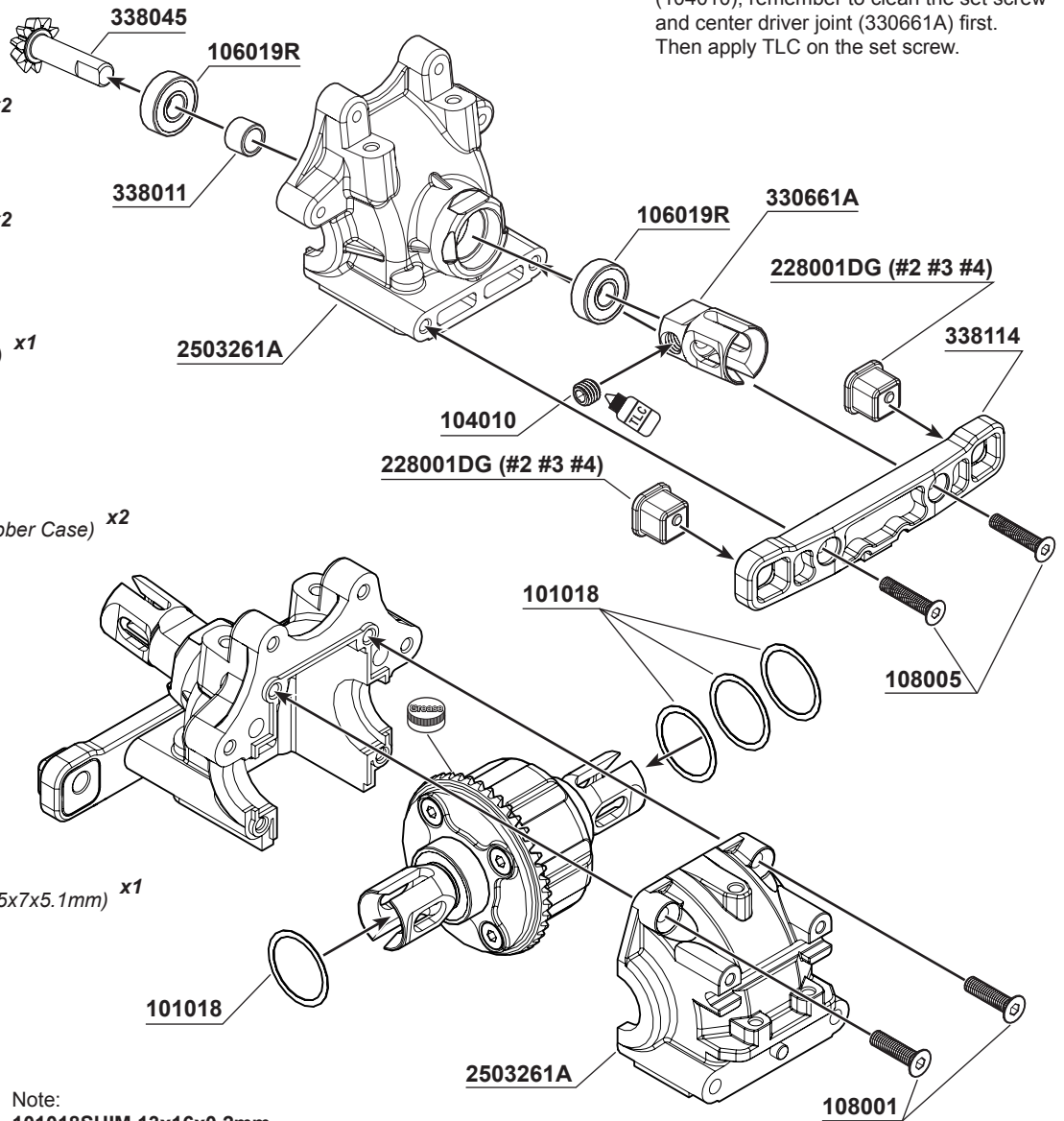

Note:
101018SHIM 13x16x0.2mm
Please use 13x16x0.2mm shims to adjust the play between the crown gear and pinion gear. Standard suggestion is 1pc shim on the diff crown gear side and 3 pcs on the other side.

BAG E1

7 L R x2

106005
M3x15mm Hex Socket OH/TP Screw x2

106021A
M4x10mm Hex Socket OH/TP Screw x2

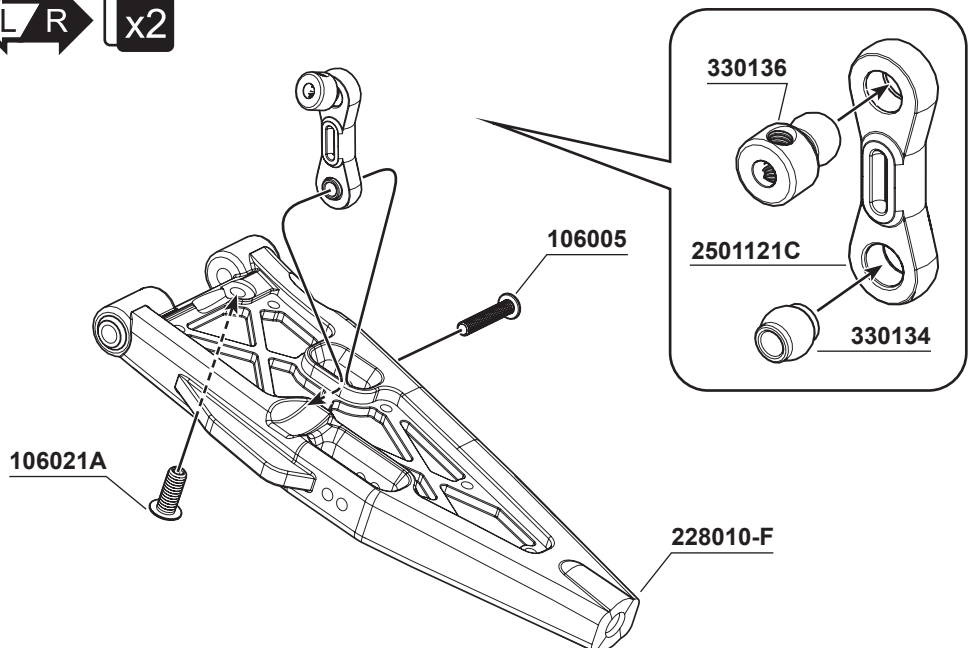

338056
S35-4 Series Lower Arm Hinge Pin (68.5mm) x2

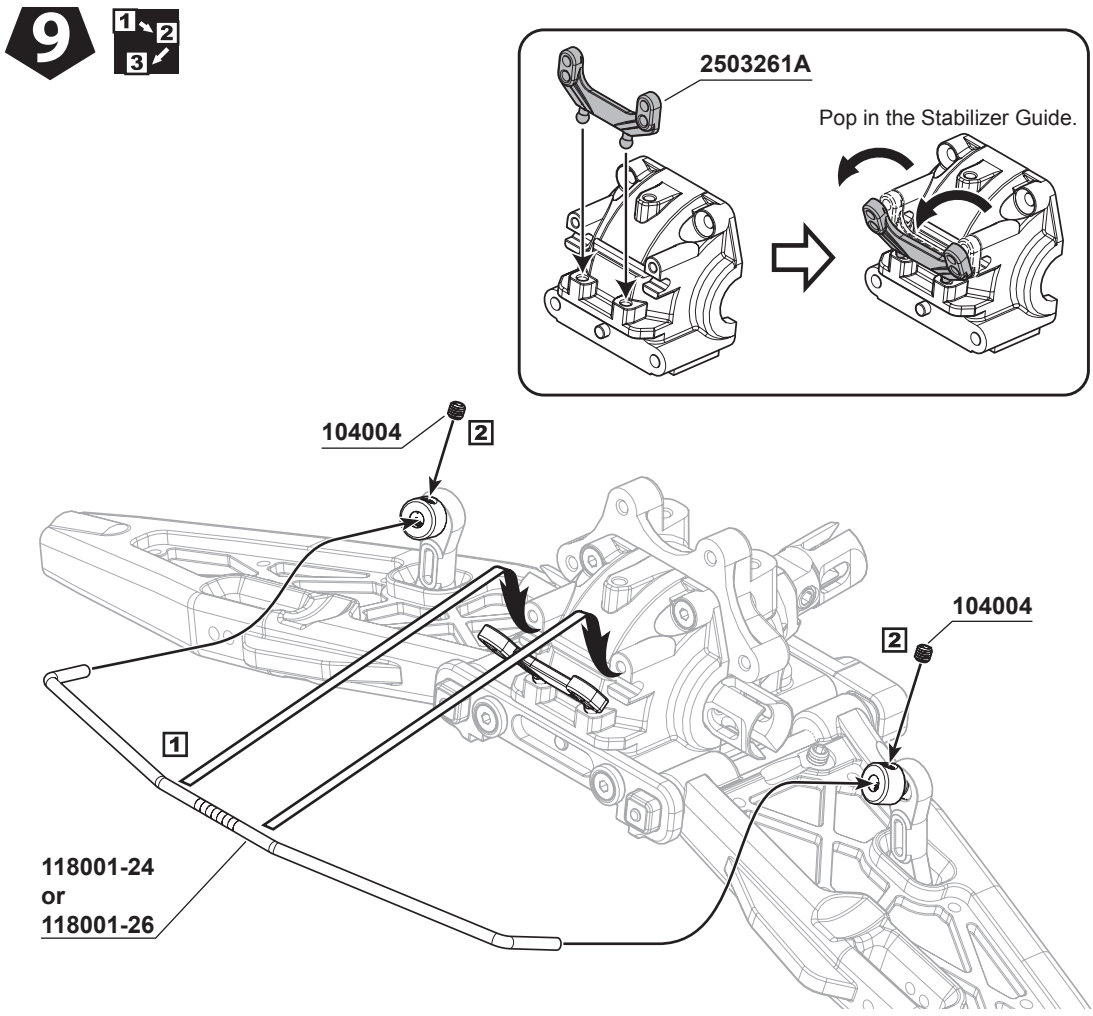
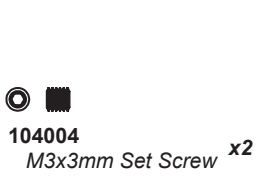
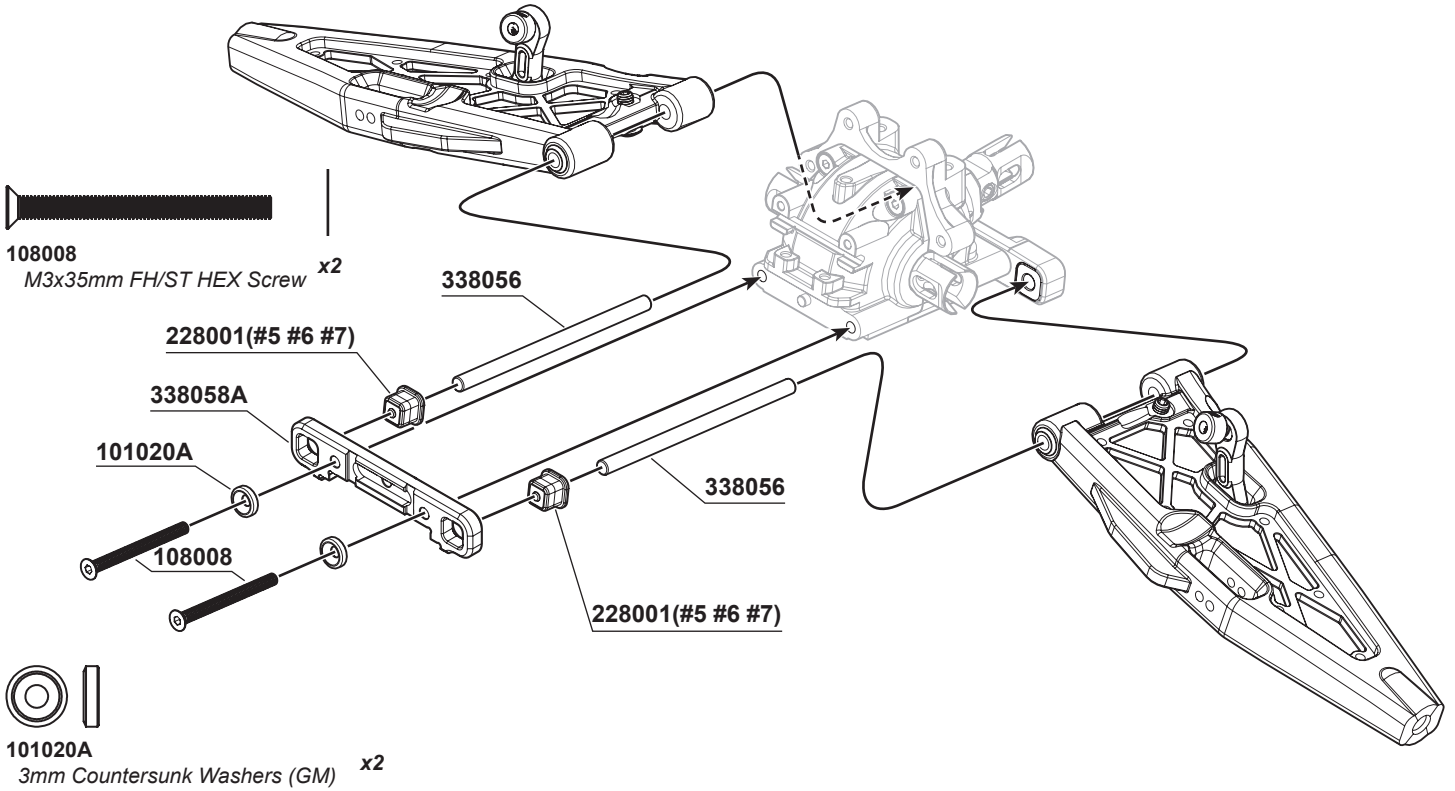

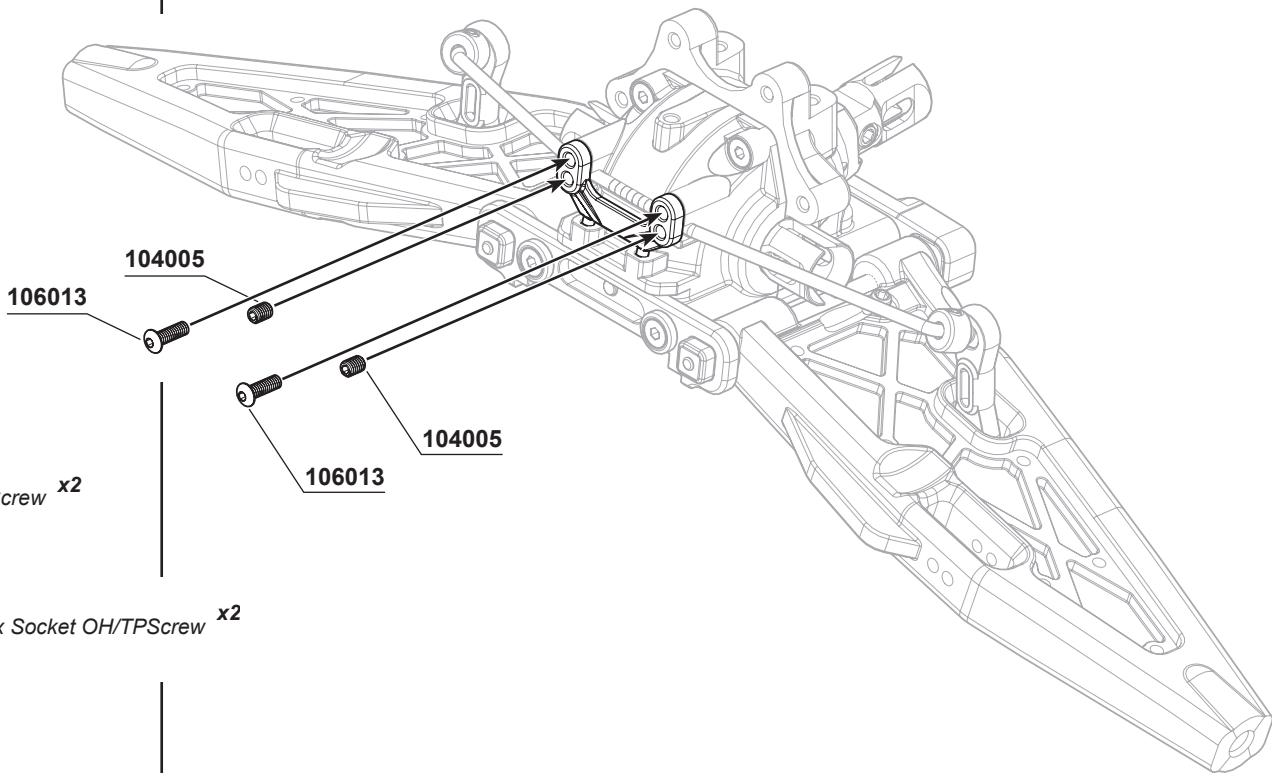

 **104005**
M3x4mm Set Screw x2

 **106013**
M2.5x8mmH ex Socket OH/TPScrew x2

11  **x2**

Note:
The aluminum front upper arm holder (338057) can offer either 0° or + -1° kick-up for your front upper arm suspension.
You may use the inserts 228001DG(#13) to get 0° kick-up or 228001DG(#12) to get + -1° for your front upper suspension.

 **108003**
M3x10mm FH/ST HEX Screw x2

 **108006**
M3x8mm FH/ST HEX Screw x2

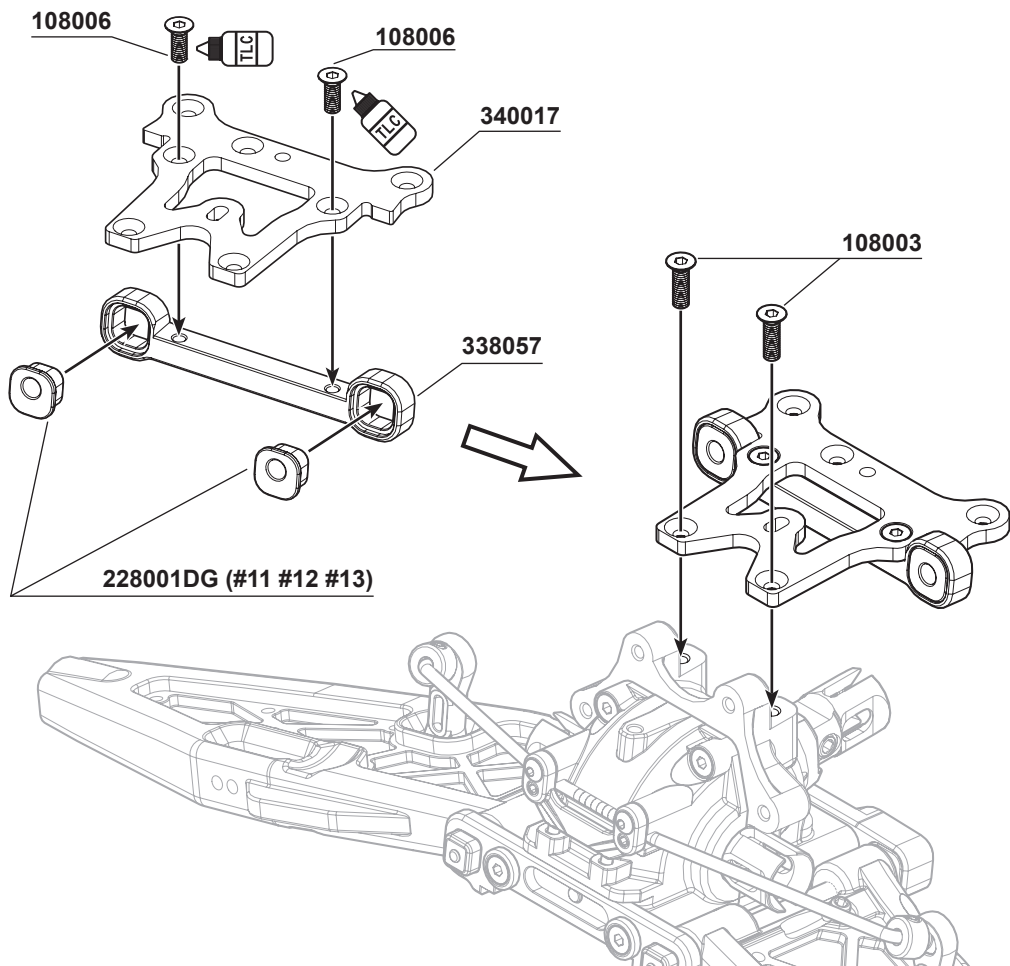



108001
M3x12mm FH/ST HEX Screw **x4**



106015
M3x5mm Hex Socket OH/TP Screw **x2**

2502040-02

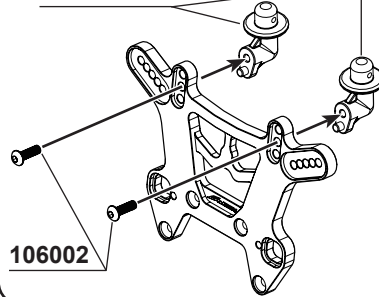

106002

PRO TIP:

The S35-T2 EVO Front Upper Arm Adjust Inserts can give different steering adjustments (Ackerman). Put all inserts behind the front upper arms, you will get faster steering response. Otherwise put all inserts in front of the upper arms, you will get more stable steering response. Try to use 2503260-1 or 2503260-3 to adjust the front upper arm position.

228011

2503260(#1 #2 #3 #4)

338085

330119

228001DG (#14 #15 #16)

2503260(#1 #2 #3 #4)

106015

330119

108001

228001DG
(#14 #15 #16)

106015

106020

340028-10

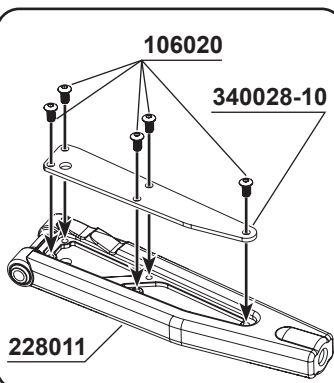

228011

228011

Note:

2503260-1
S35-3 Front Upper Arm Adjust Insert (0.9mm)
2503260-2
S35-3 Front Upper Arm Adjust Insert (1.0mm)
2503260-3
S35-3 Front Upper Arm Adjust Insert (1.1mm)
2503260-4
S35-3 Front Upper Arm Adjust Insert (2.0mm)

330119

Front Upper Arm Hinge Pin **x2**

106005
M3x15mm Hex Socket OH/TP Screw **x2**



106021A
M4x10mm Hex Socket OH/TP Screw **x2**

106021A

106005

228010-R

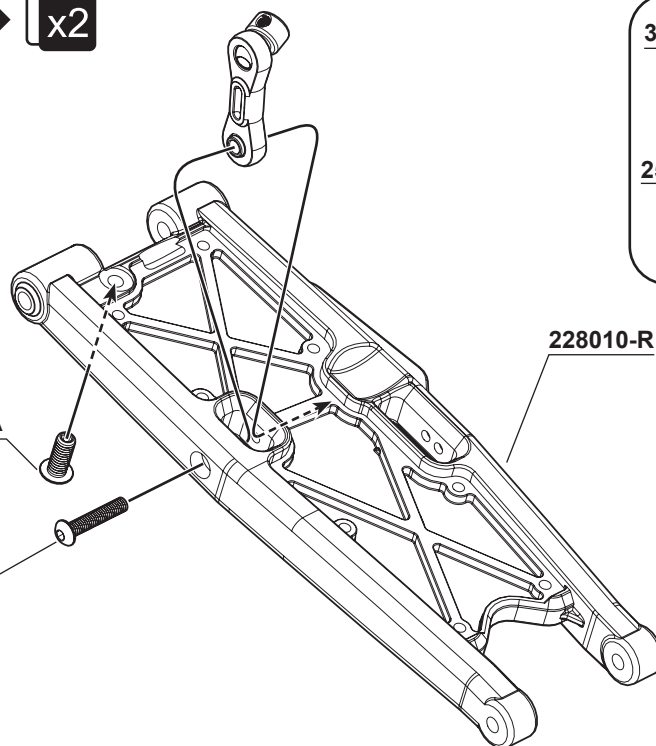

330136

2501121C

330134



108001
M3x12mm FH/ST HEX Screw x4



108005
M3x14mm FH/ST HEX Screw x2



106002
M3x10mm Hex Socket OH/TP Screw x2

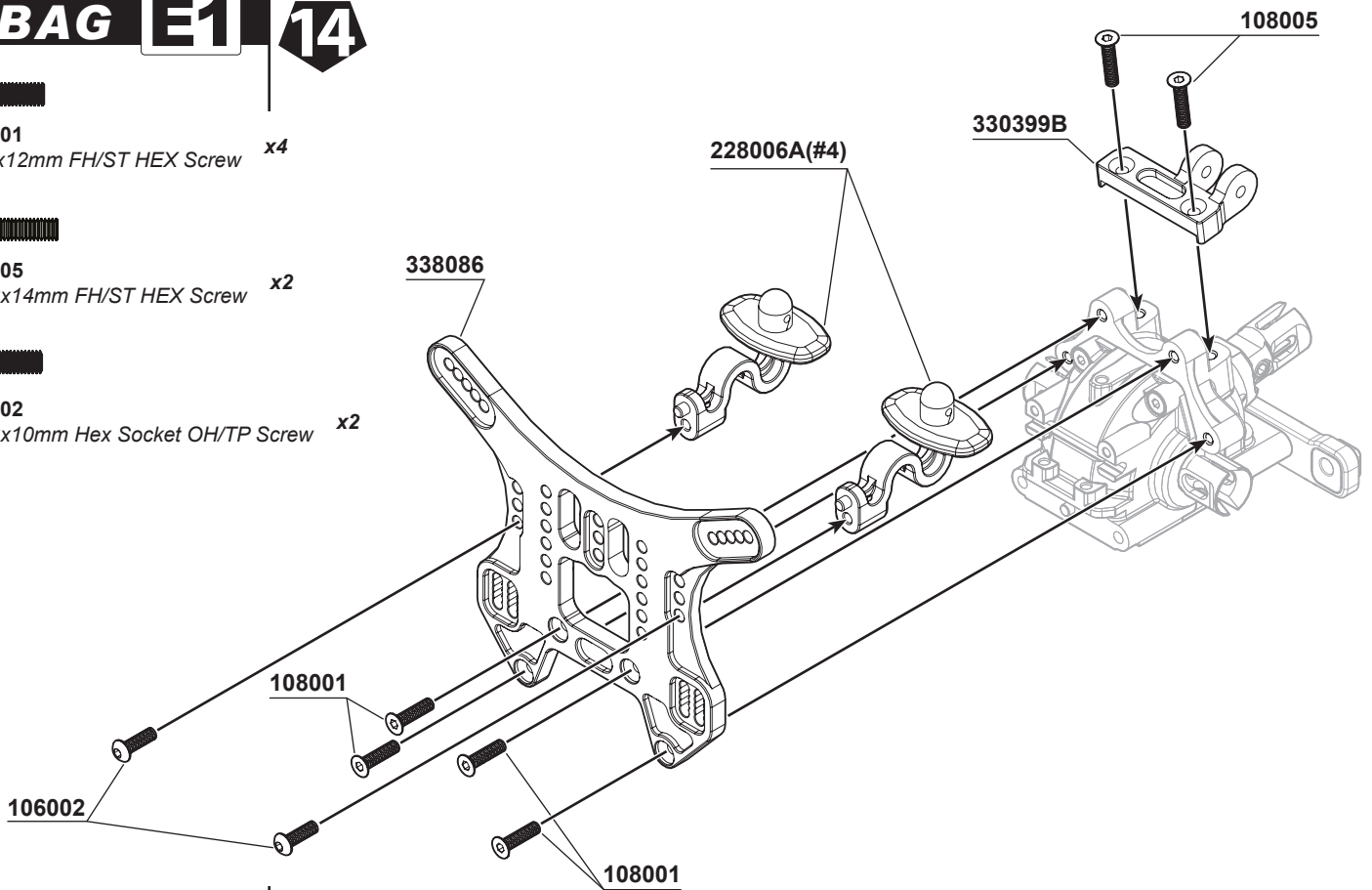

15



108008
M3x35mm FH/ST HEX Screw x2

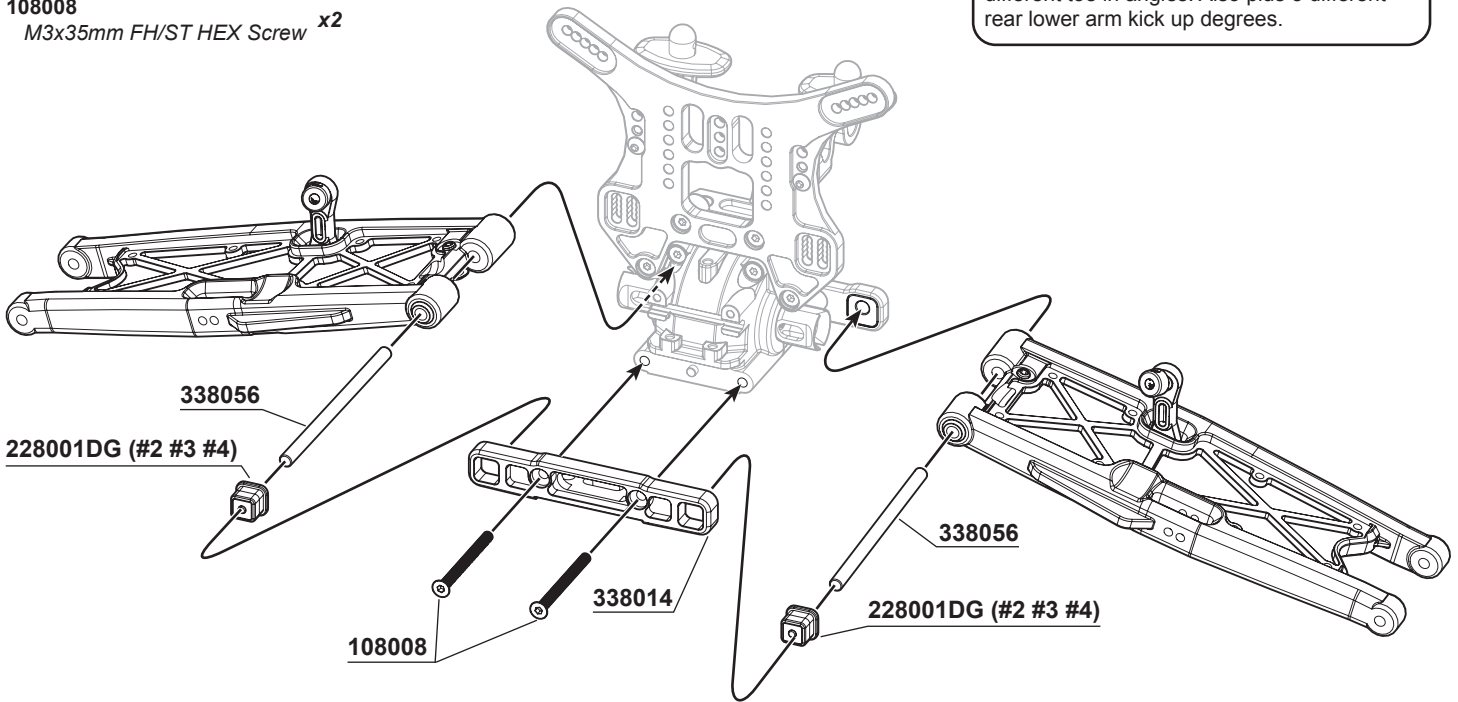

PRO TIP:
The S35-T2 EVO Aluminum Rear Lower Fully Adjustable Toe-In Block (338014) can use 3 types of square inserts to get 1.0/2.0/3.0 3 different toe in angles. Also plus 3 different rear lower arm kick up degrees.

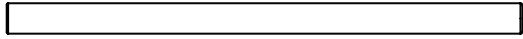

338056
S35-4 Series Lower Arm Hinge Pin (68.5mm) x2

OPTION:
228001DG-2 S35-4 Series Rear Lower Arm Holder Square Insert (+1/+1)
228001DG-3 S35-4 Series Rear Lower Arm Holder Square Insert (0/+1)
228001DG-4 S35-4 Series Rear Lower Arm Holder Square Insert (0)



104004
M3x3mm Set Screw x2

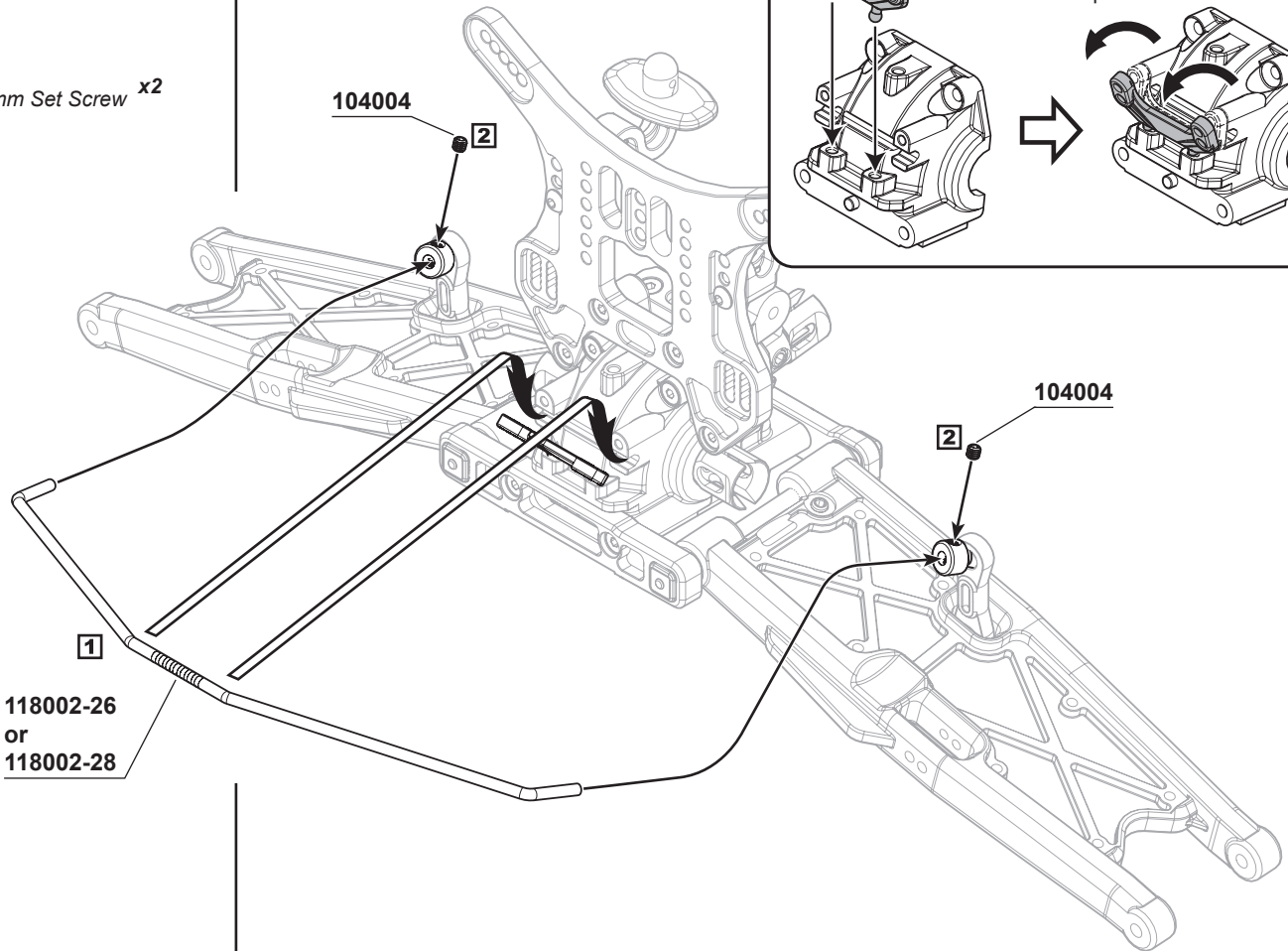

104005
M3x4mm Set Screw x2



106013
M2.5x8mmH ex Socket OH/TPScrew x2

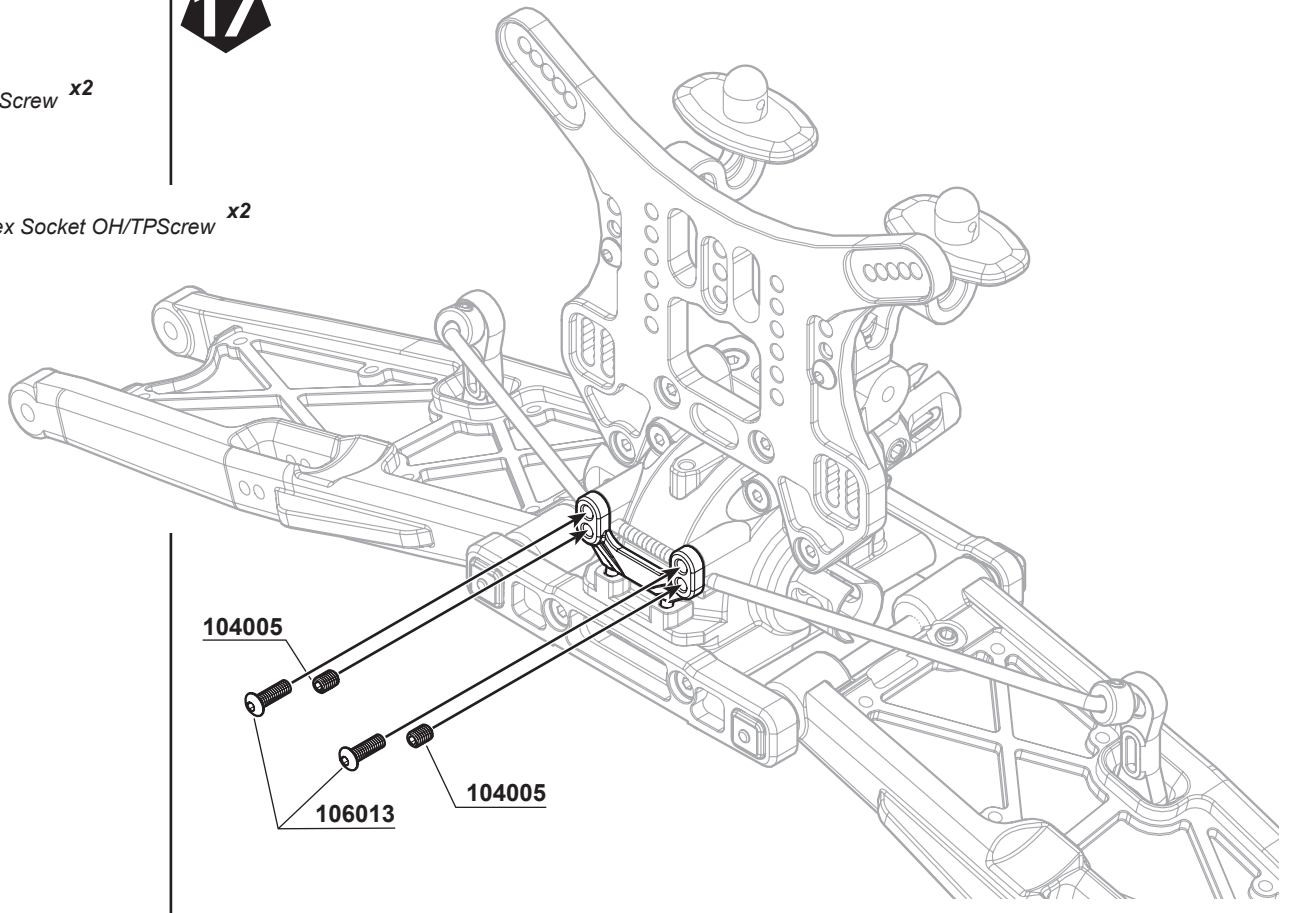



106002
M3x10mm Hex Socket OH/TP Screw x4

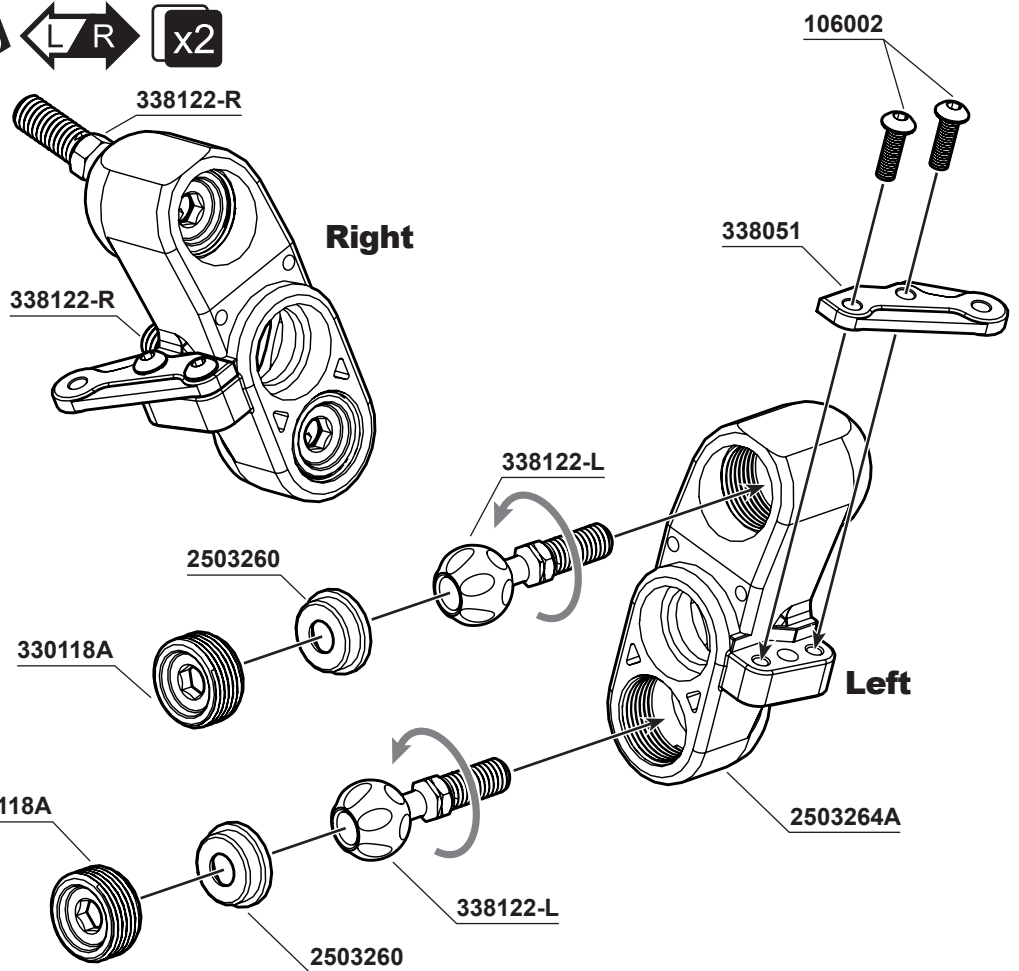

Screw and adjust 330118A Knuckle Pivot Ball Nut so as the pivot ball can be moved smoothly.



116006R
Ball Bearing 8x16x5mm (Red Rubber Case) x4

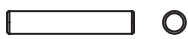

330124
Pin M3.0x16.8mm x2

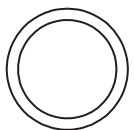

101018
SHIM 13x16x0.2mm x1



104010
M5x4mm Set Screw (Flat Bottom) x2

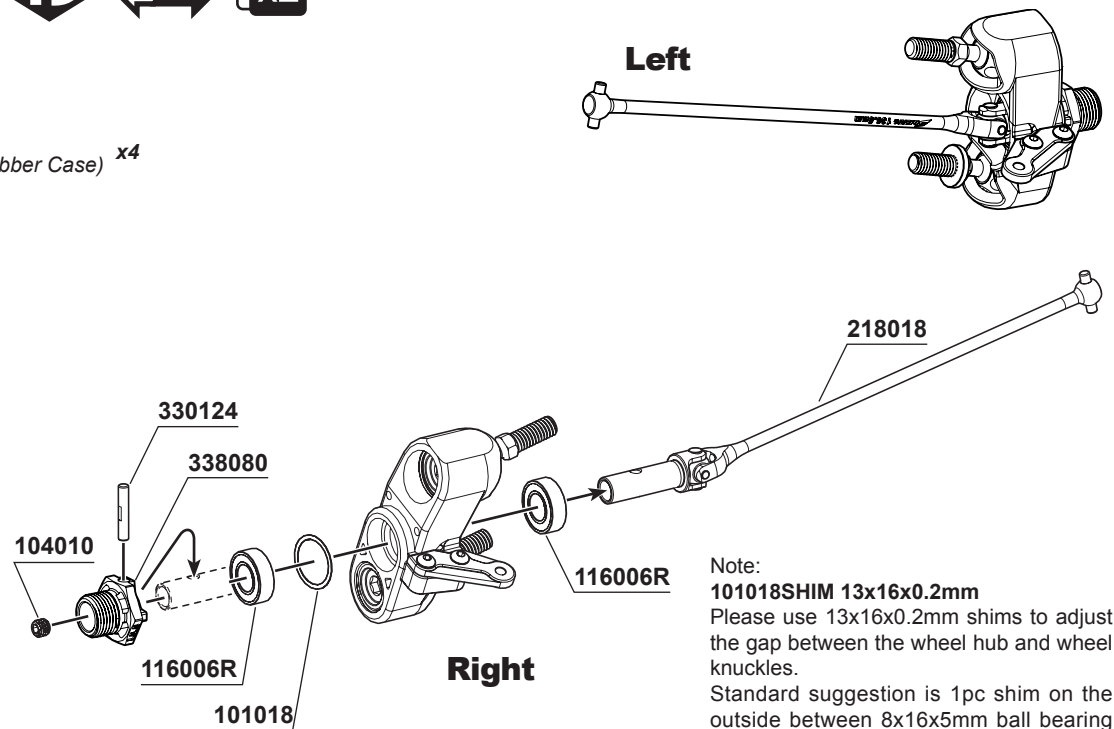

Note:
101018SHIM 13x16x0.2mm
Please use 13x16x0.2mm shims to adjust the gap between the wheel hub and wheel knuckles.
Standard suggestion is 1pc shim on the outside between 8x16x5mm ball bearing and knuckle.
If the wheel hub still has big play with knuckle, please try to put another shim in another side between ball bearing and knuckle.

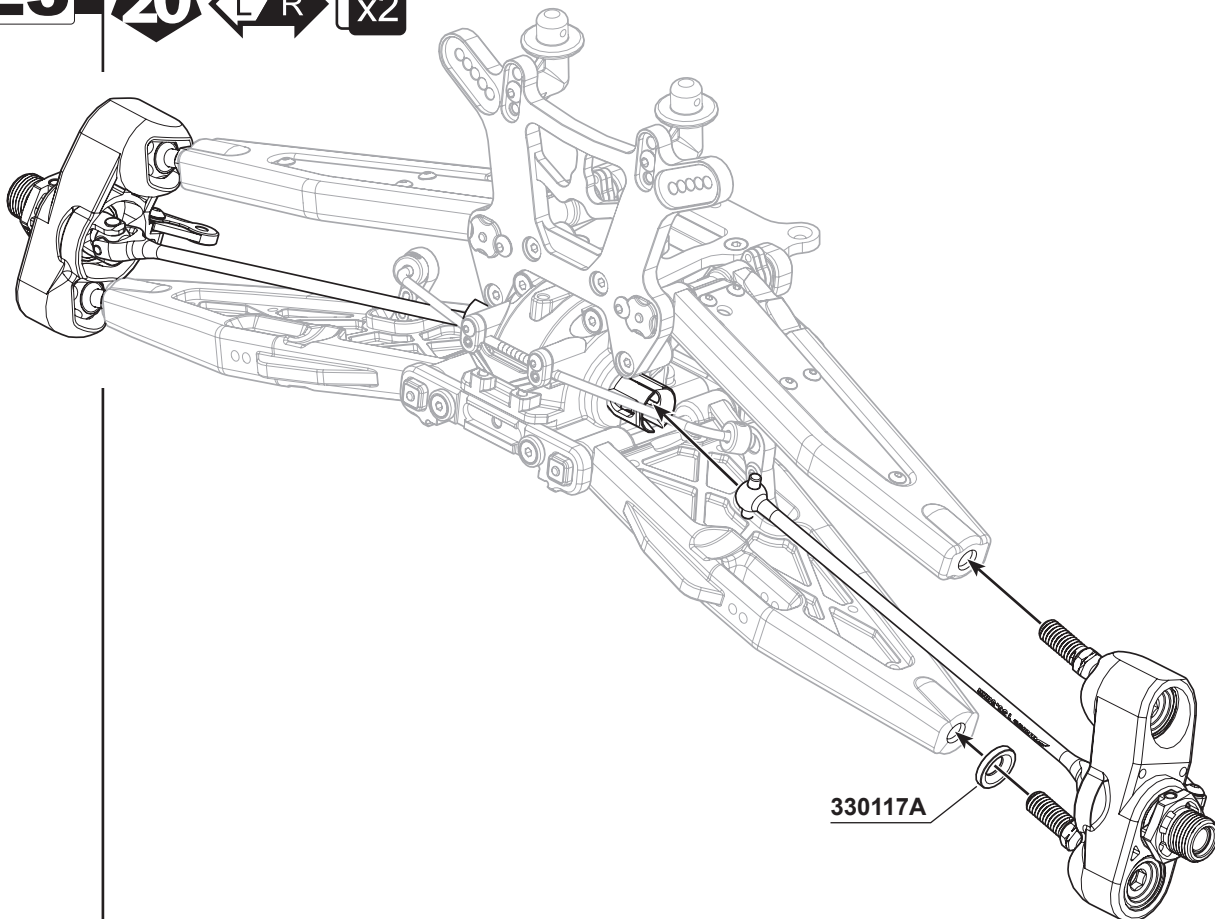
BAG**E3****20****x2****BAG****E2****21**

103001
M3 Nut Lock x2



101012
M3x6xT0.6mm x2



117003
Flange Ball Bearing 3x6x2.5mm x4



106007
M3x12mm Hex Socket
OH/TP Screw(HT) x2



116004R
Ball Bearing 6x10x3mm (Red Rubber Case) x2



105018
M2x6mm Cap Screw x1

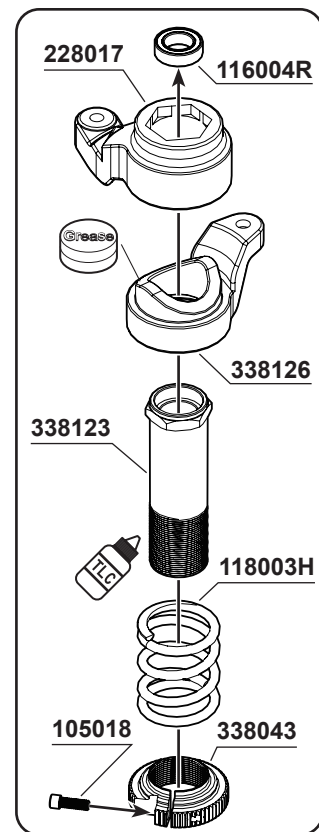
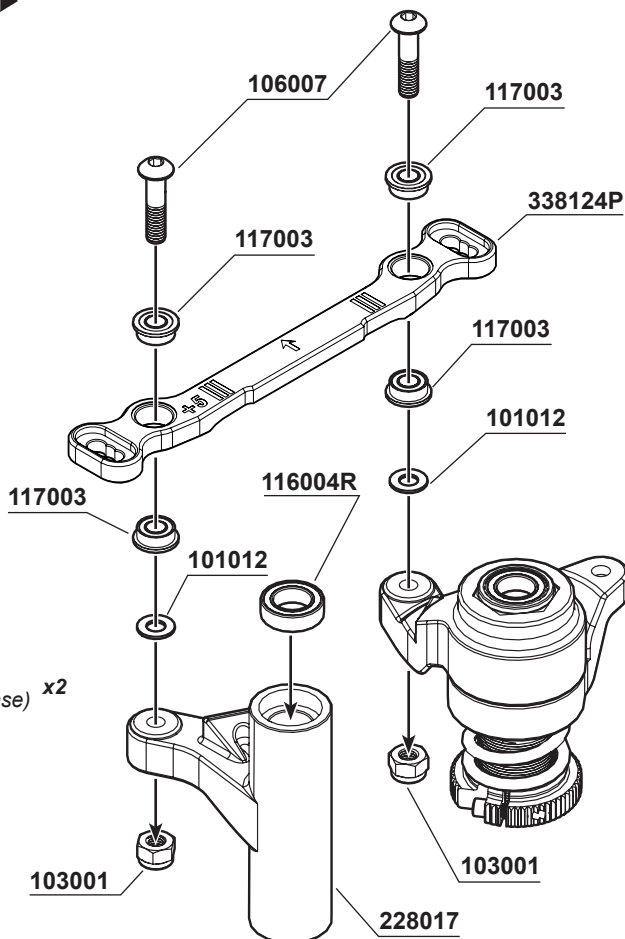

BAG E2

22



108003
M3x10mm FH/ST HEX Screw x2



116004R
Ball Bearing 6x10x3mm (Red Rubber Case) x2



101019
SHIM 6.0x10.0x0.2mm x1

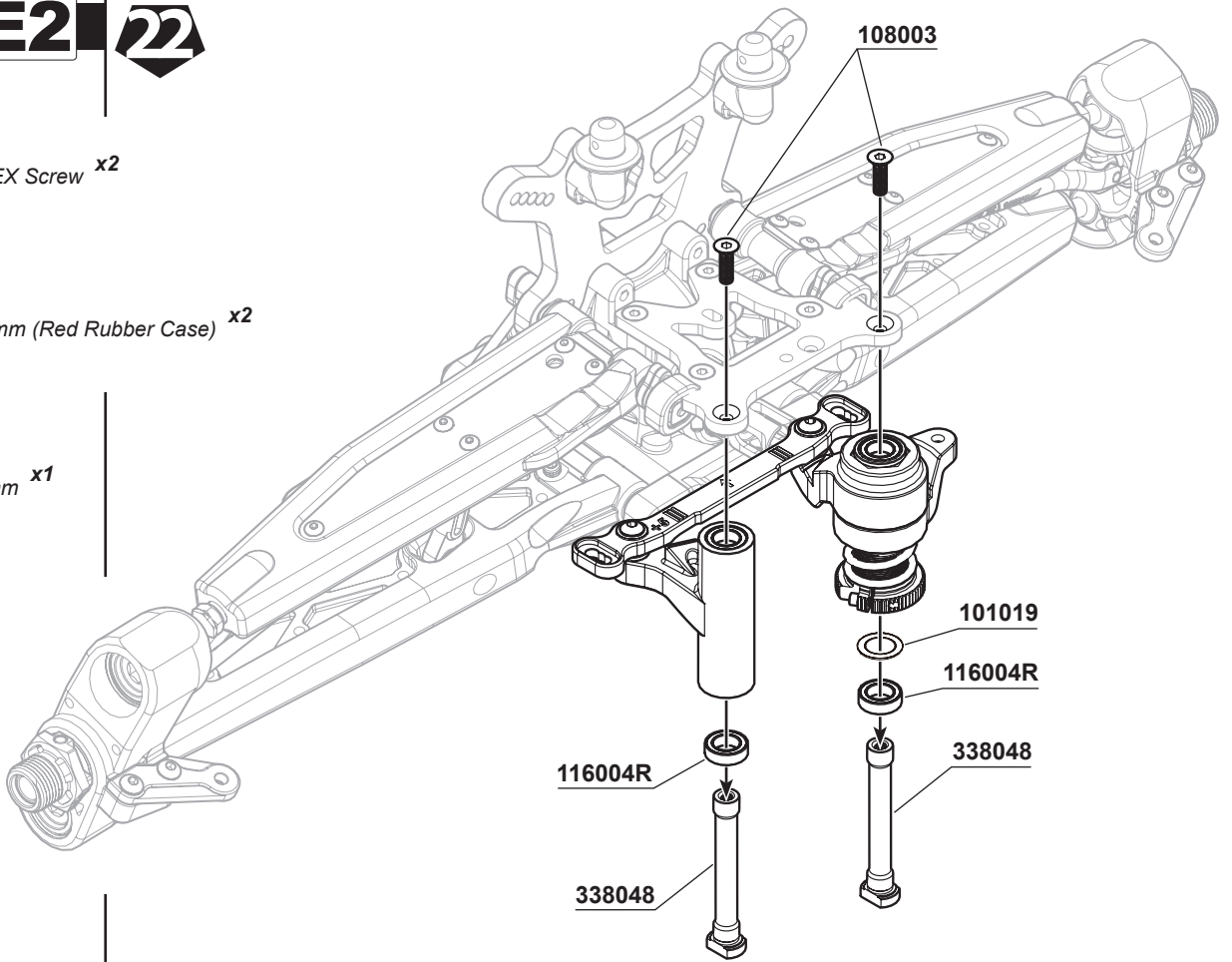

BAG E3

23

1 2 3 L R x2



103001
M3 Nut Lock x4



104010
M5x4mm Set Screw (Flat Bottom) x2

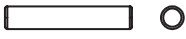

330124
Pin M3.0x16.8mm x2



106009
M3x25mm Hex Socket OH/TP Screw x4



116006R
Ball Bearing 8x16x5mm (Red Rubber Case) x4

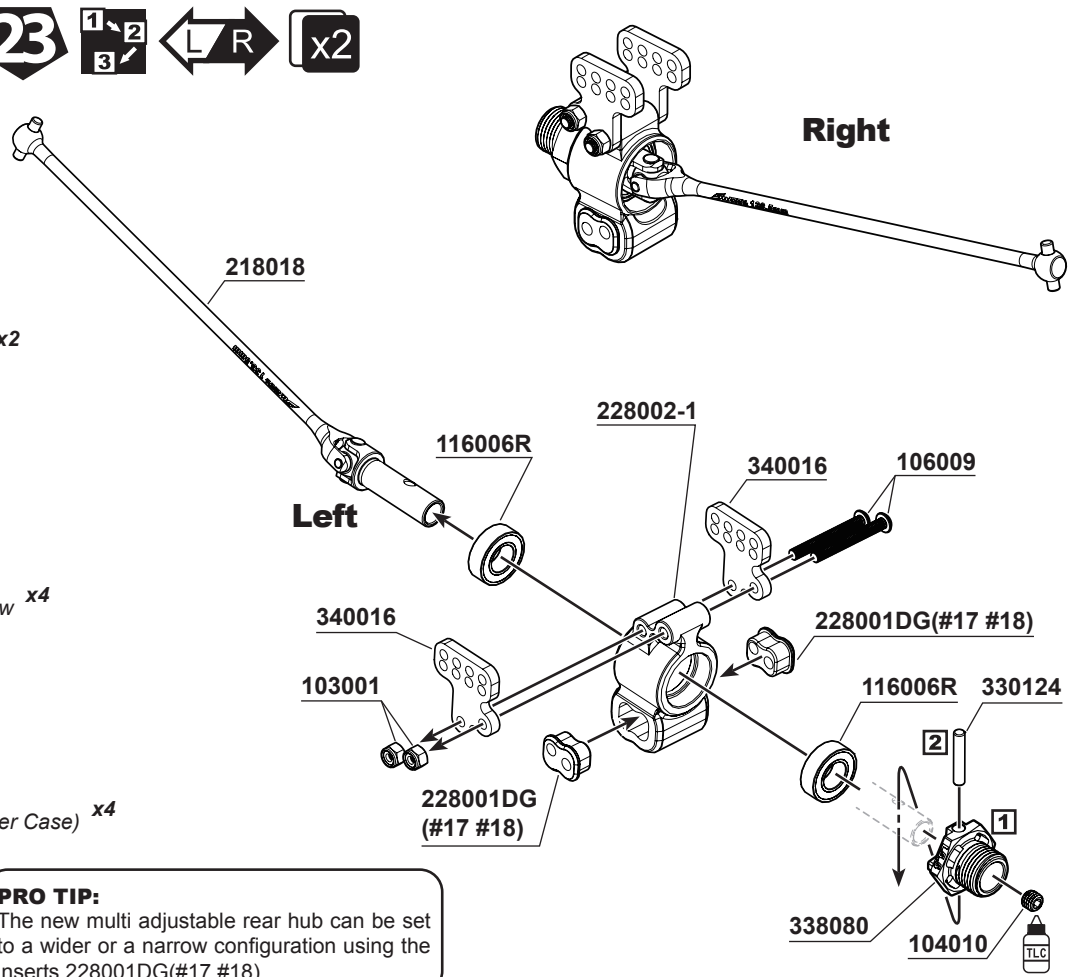

PRO TIP:
The new multi adjustable rear hub can be set to a wider or a narrow configuration using the inserts 228001DG(#17 #18)

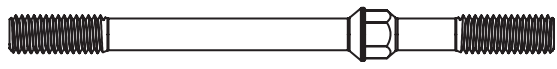
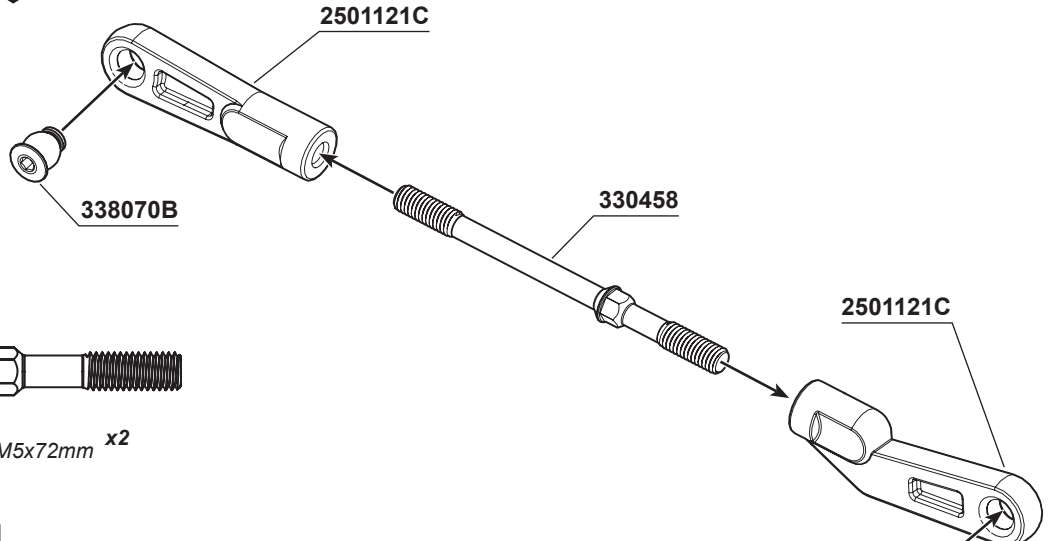
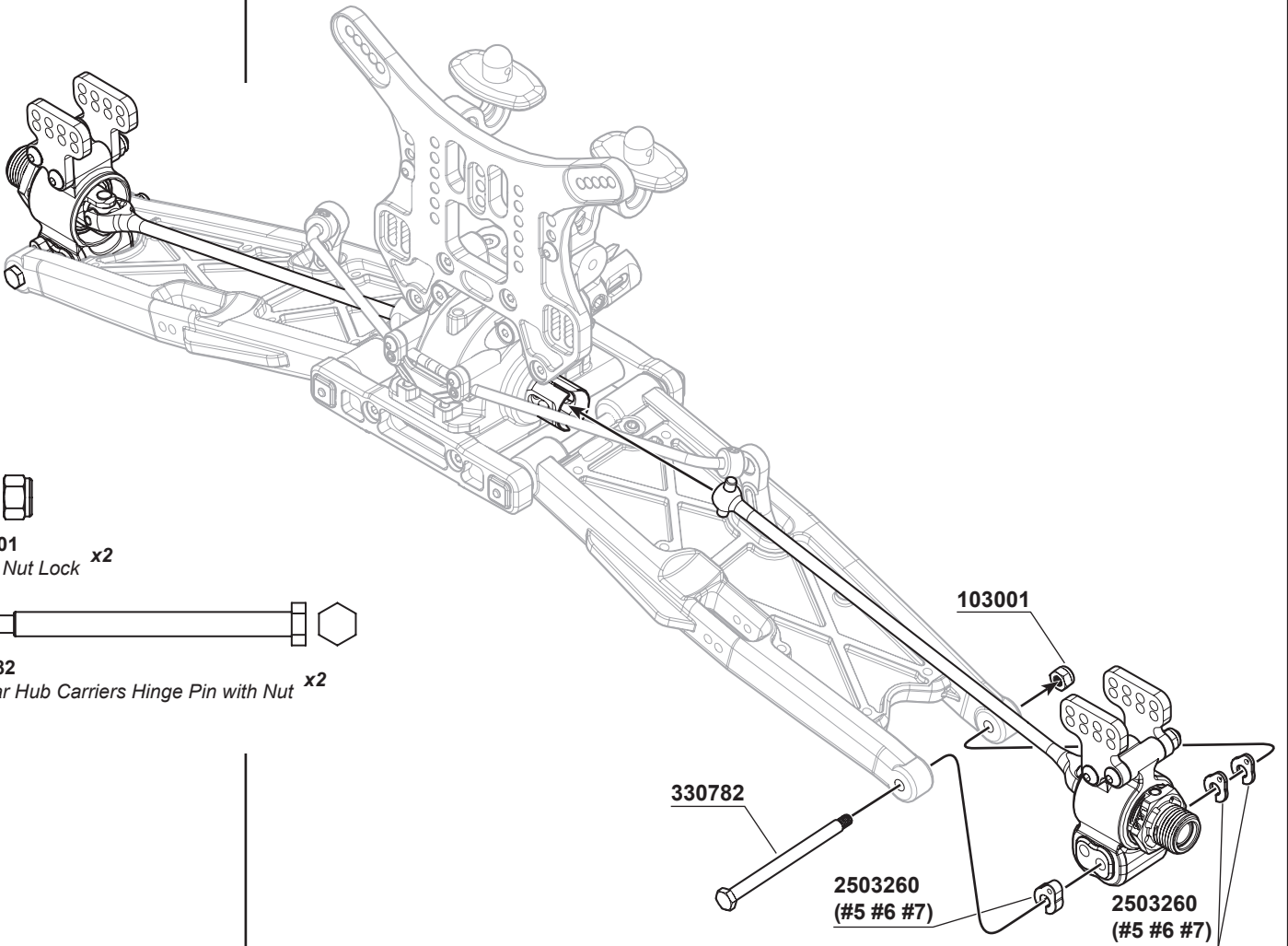

330458
S350T Rear Upper Arm Turnbuckle M5x72mm x2

1:1

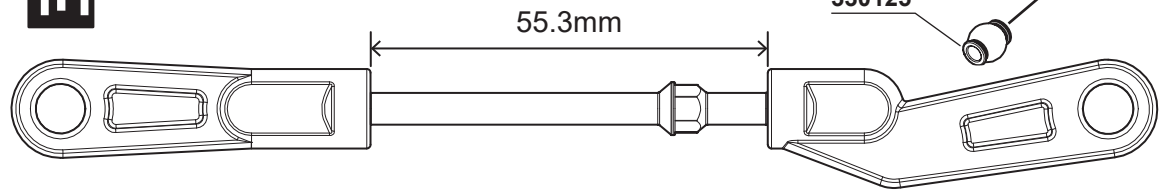



106002
M3x10mm Hex Socket OH/TP Screw x2



106009
M3x25mm Hex Socket OH/TP Screw x2



103001
M3 Nut Lock x2

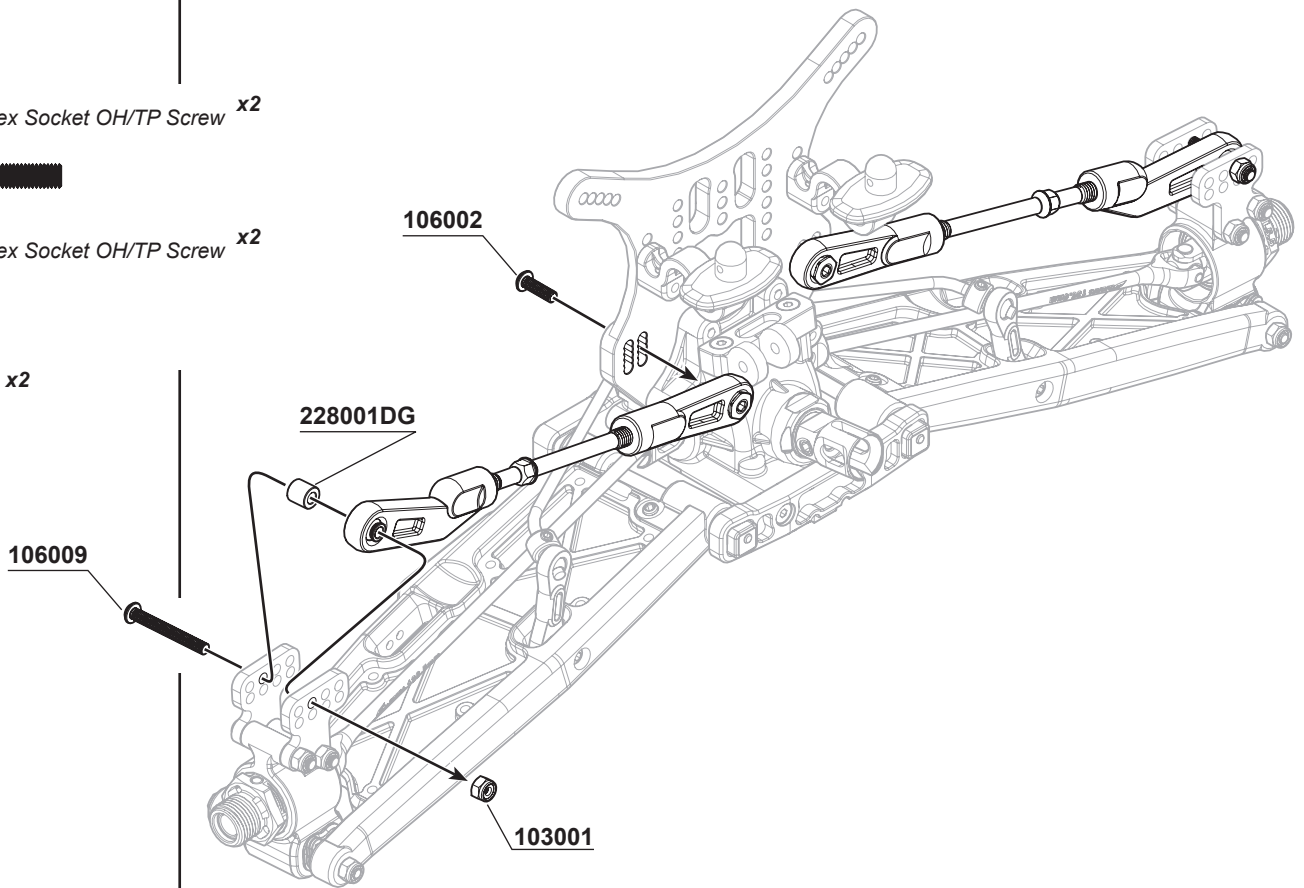

27



103001
M3 Nut Lock x6



106003
M3x16mm Hex Socket OH/TP Screw x4



108019
M2.6x6mm Flat Head Screw - Hex Socket x2

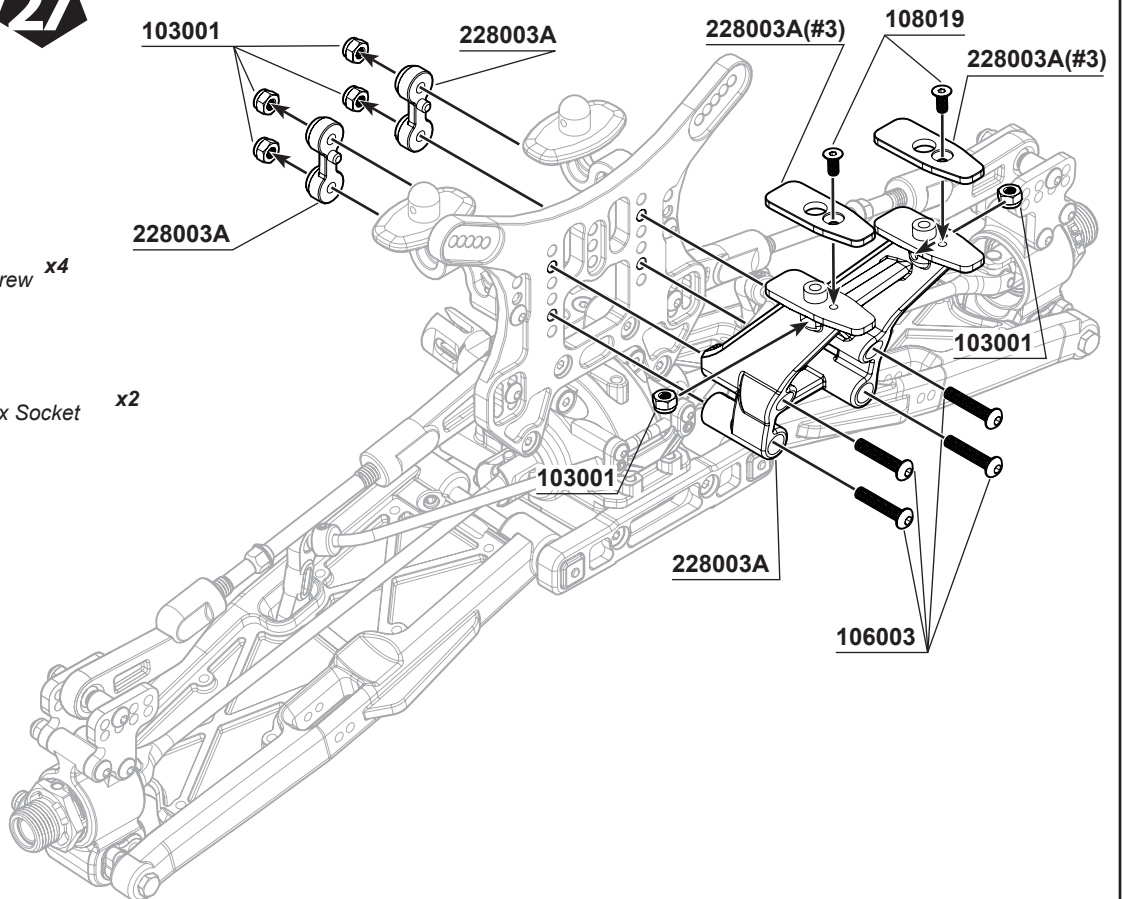



106007
M3x12mm Hex Socket OH/TP Screw(HT) x4



104004
M3x3mm Set Screw x2



108006
M3x8mm FH/ST HEX Screw x4



116009
Ball Bearing M5x8x2.5mm x2

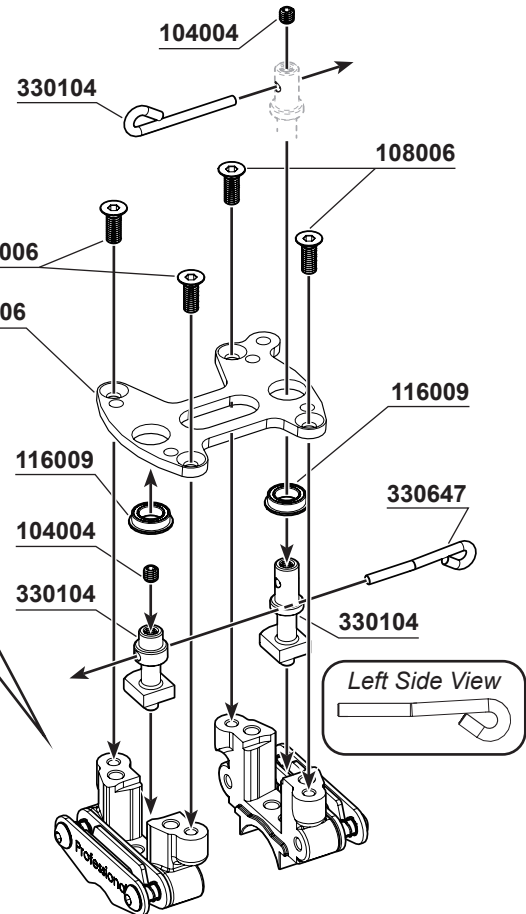
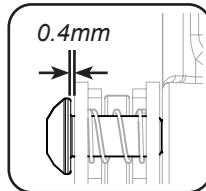
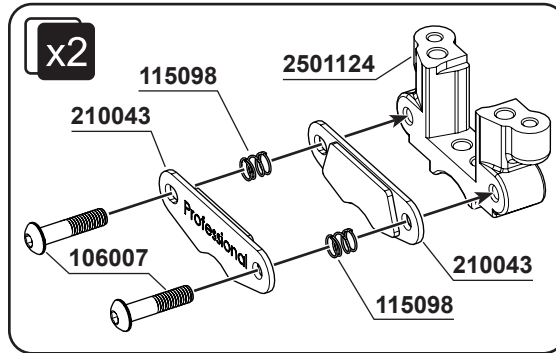

106009
M3x25mm Hex Socket OH/TP Screw x4



108007
M3x6mm FH/ST HEX Screw x2

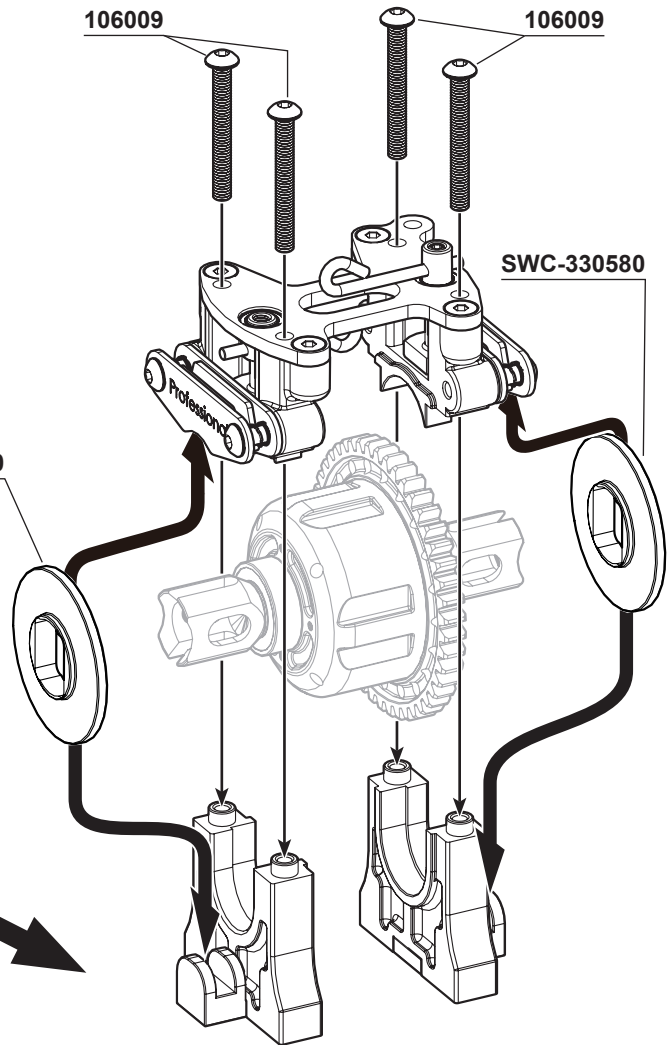
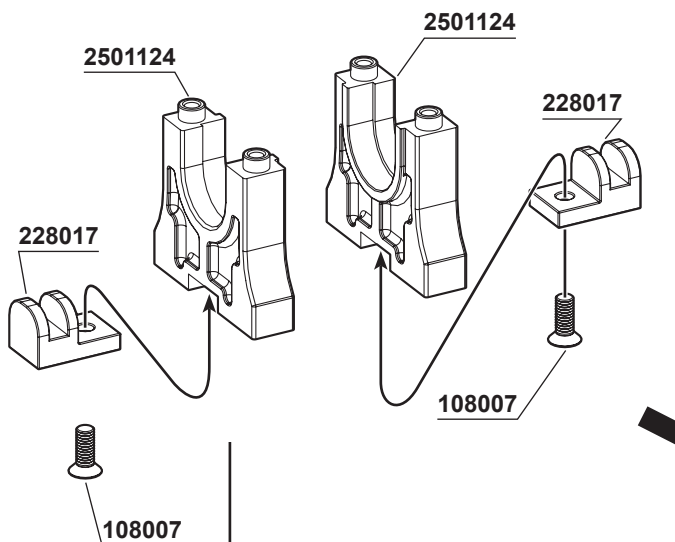



108007
M3x6mm FH/ST HEX Screw x10

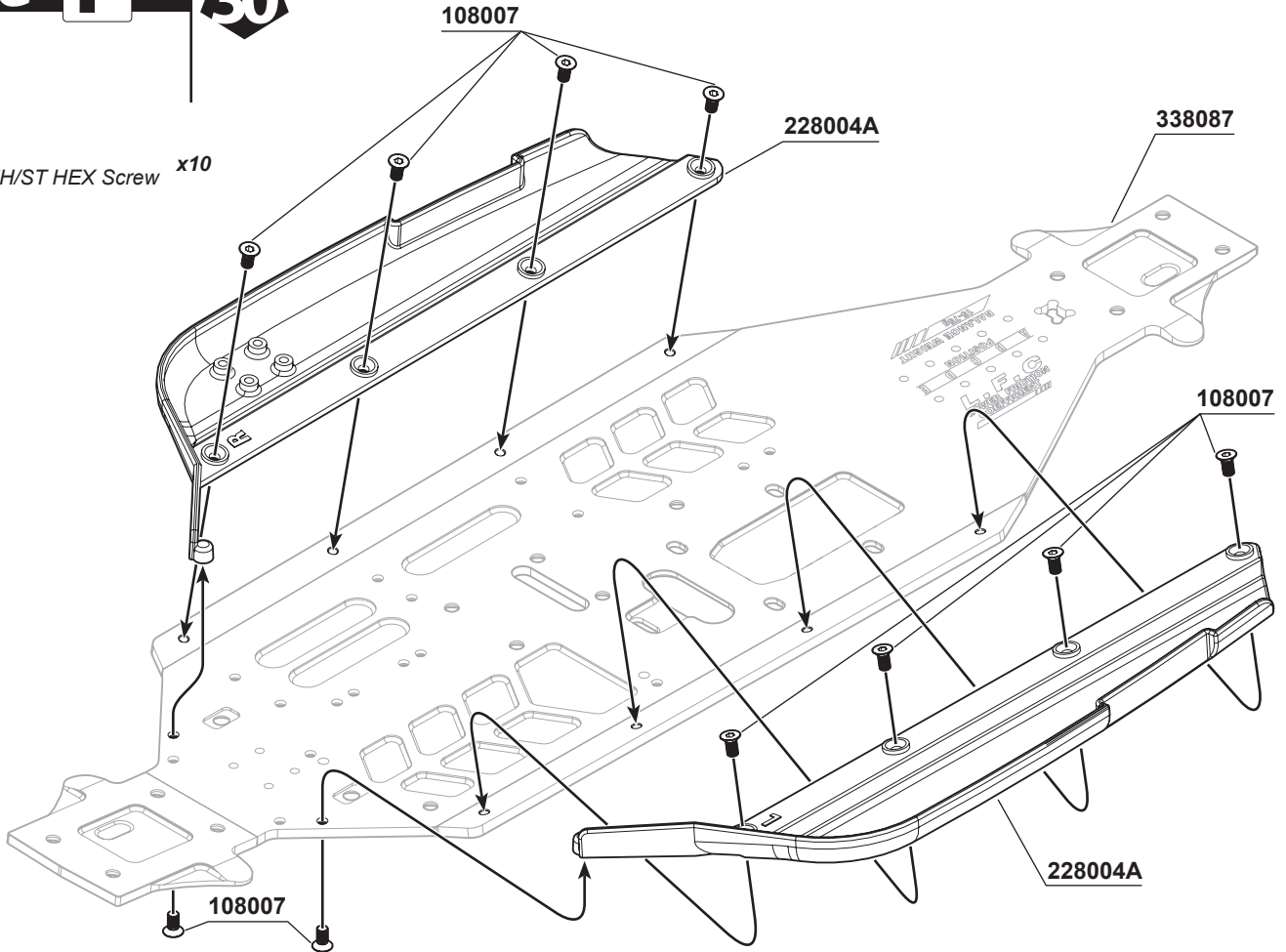

108003
M3x10mm FH/ST HEX Screw x2



108010
M4x10mm FH/ST HEX Screw x2



108012
M4x16mm FH/ST HEX Screw x4

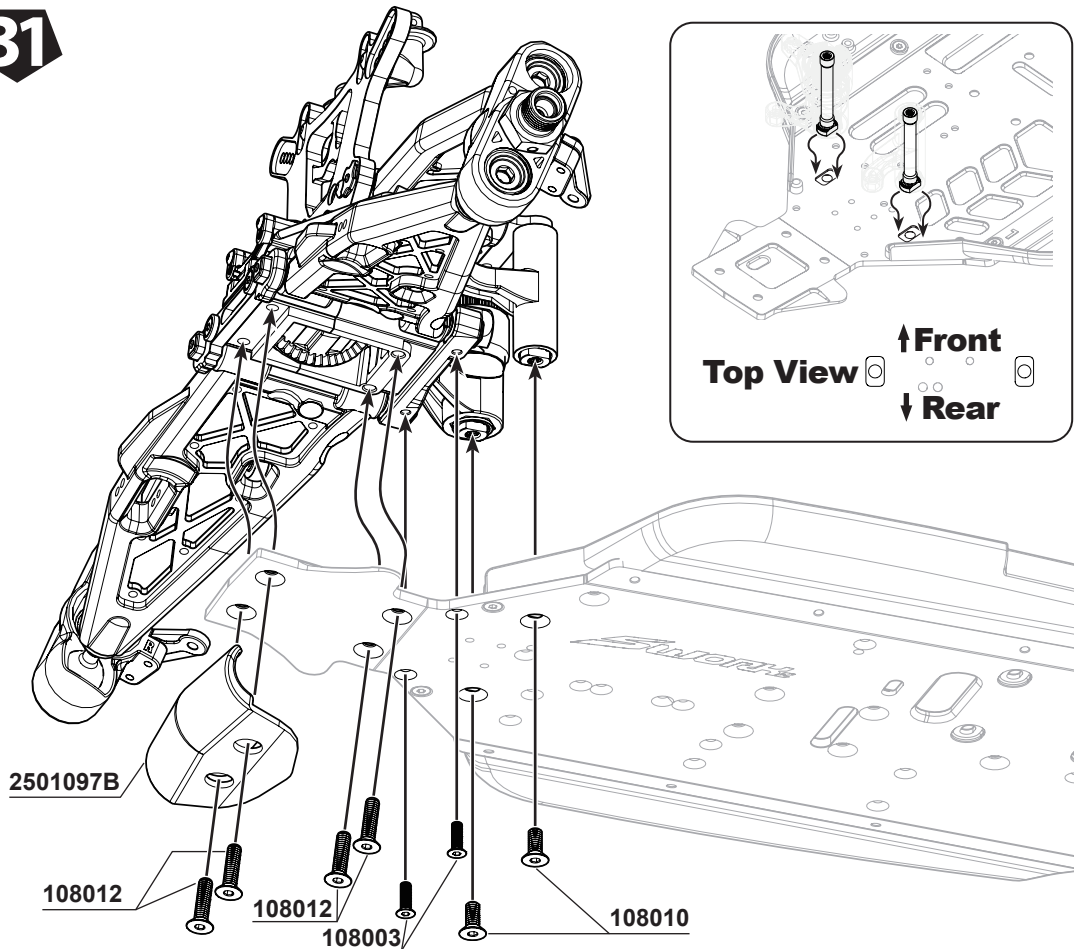



108003
M3x10mm FH/ST HEX Screw x3

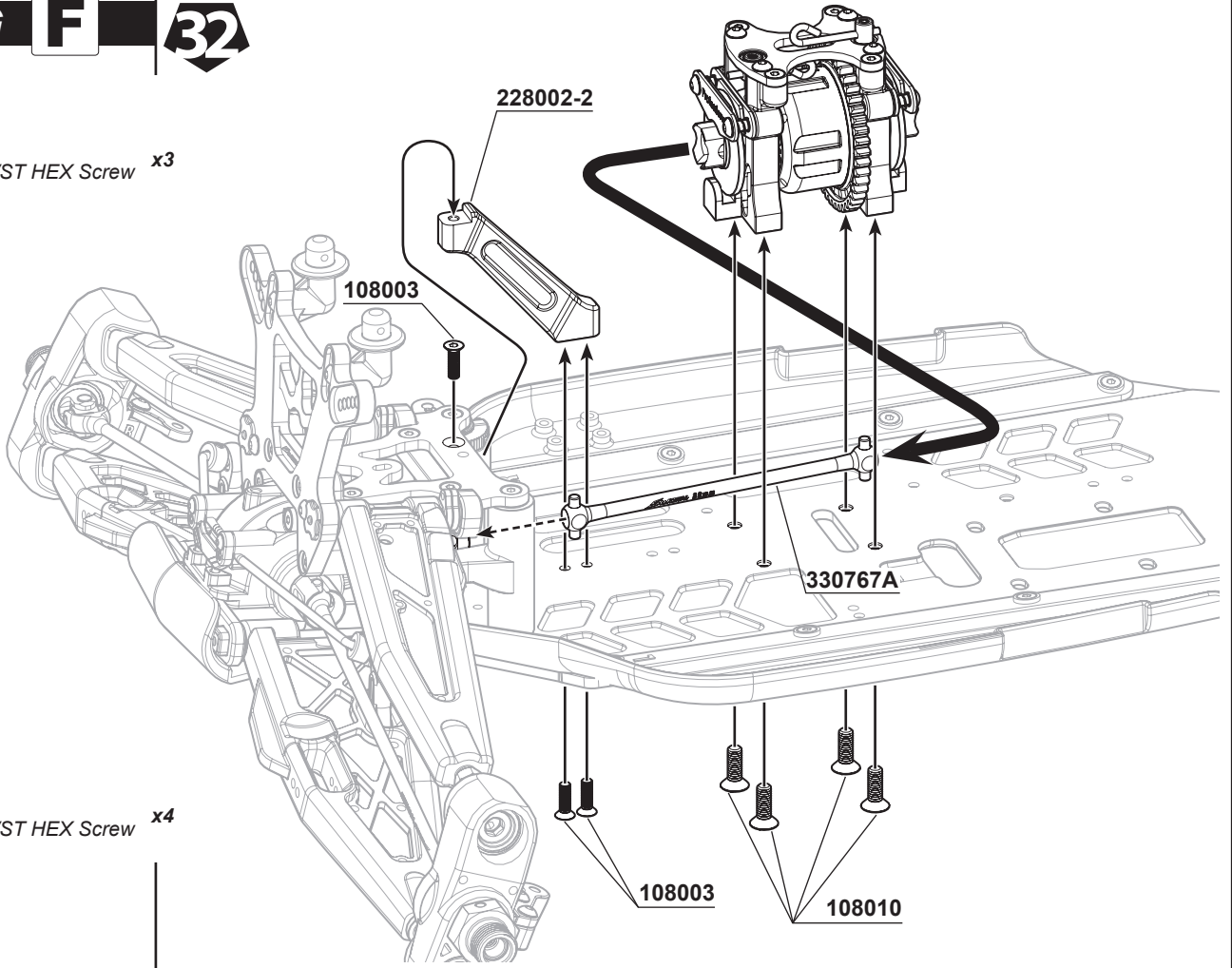

108010
M4x10mm FH/ST HEX Screw x4

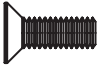

108011
M4x12mm FH/ST HEX Screw x1



108012
M4x16mm FH/ST HEX Screw x4



106006
M3x20mm Hex Socket OH/TP Screw x1



103001
M3 Nut Lock x1



103005
M4mm Nut Lock (BK) x1

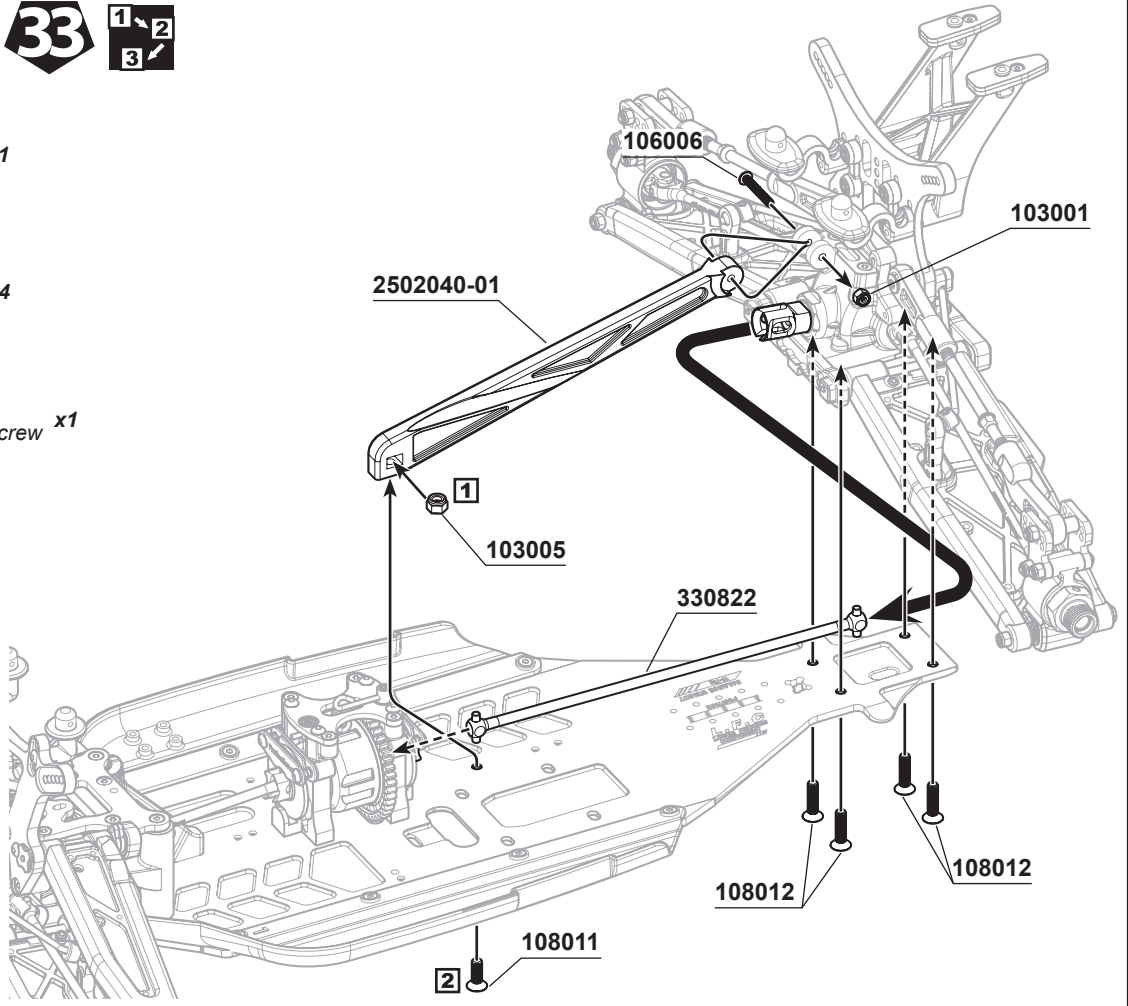

BAG

G

34



x2

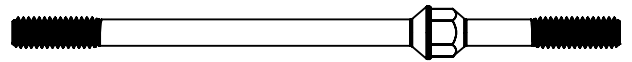

338089
Steering Linkage Turnbuckle M4x80mm **x2**

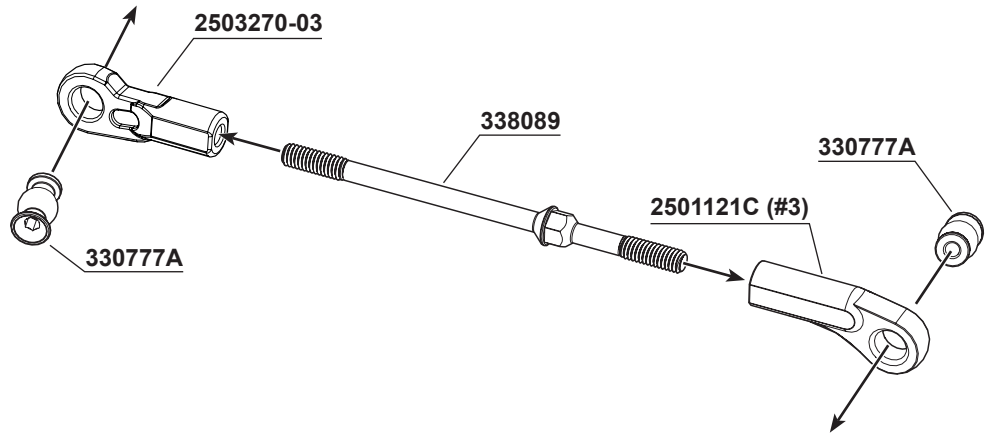

1:1

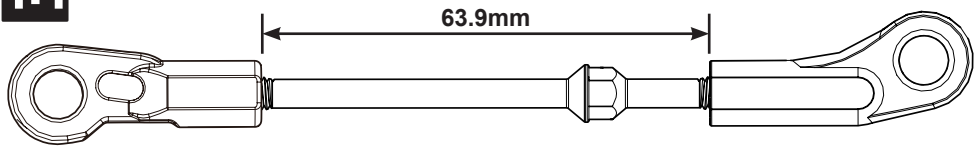

35



x2



106002
M3x10mm Hex Socket OH/TP Screw **x4**

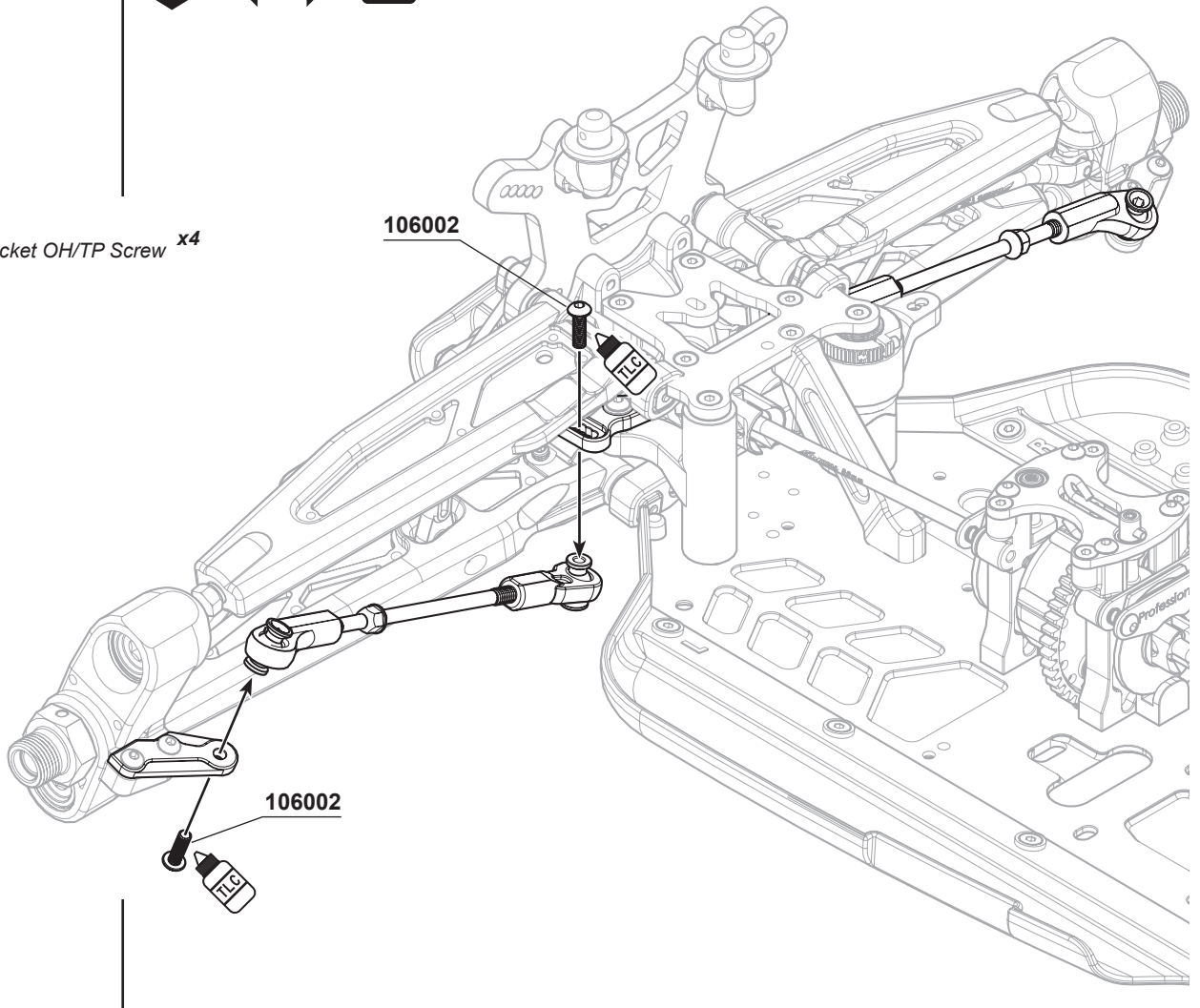



106008
M3x12mm Hex Scket OH/TP Screw **x4**



106003
M3x16mm Hex Socket OH/TP Screw **x4**

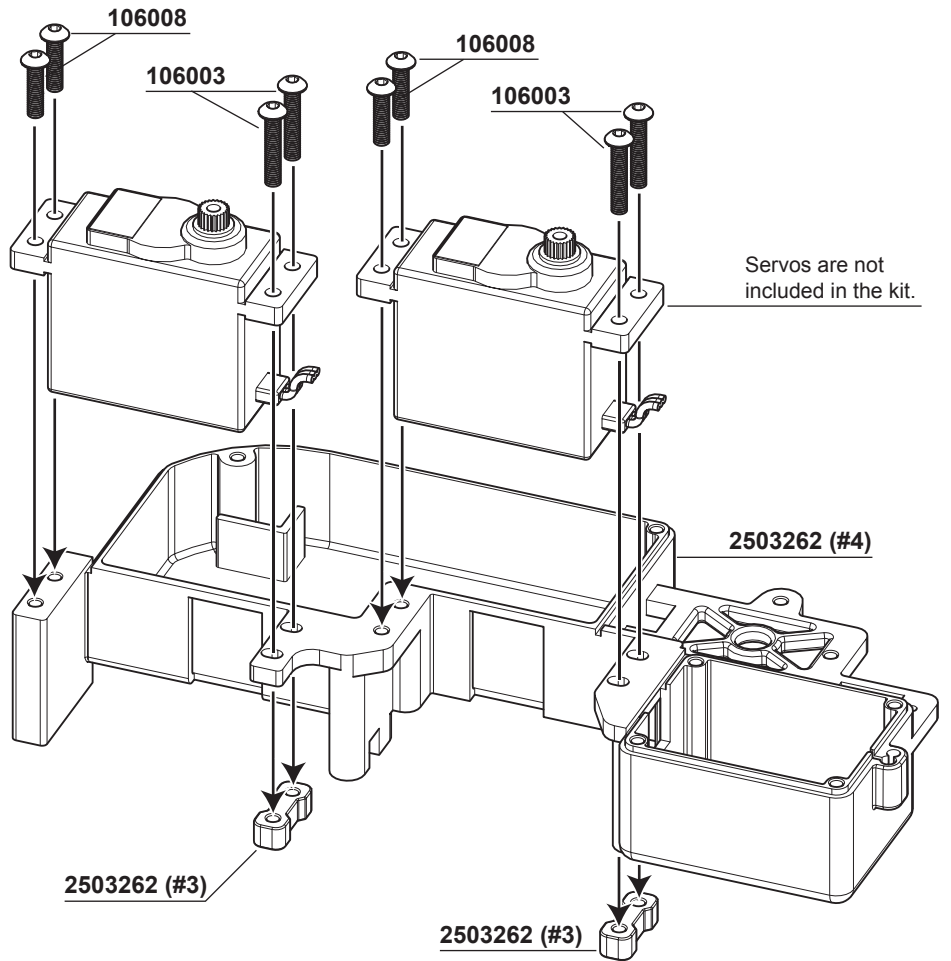

103001
M3 Nut Lock **x2**



106002
M3x10mm Hex Socket OH/TP Screw **x3**

Receiver and switch are not included in the kit.

The switch is not included in the kit.

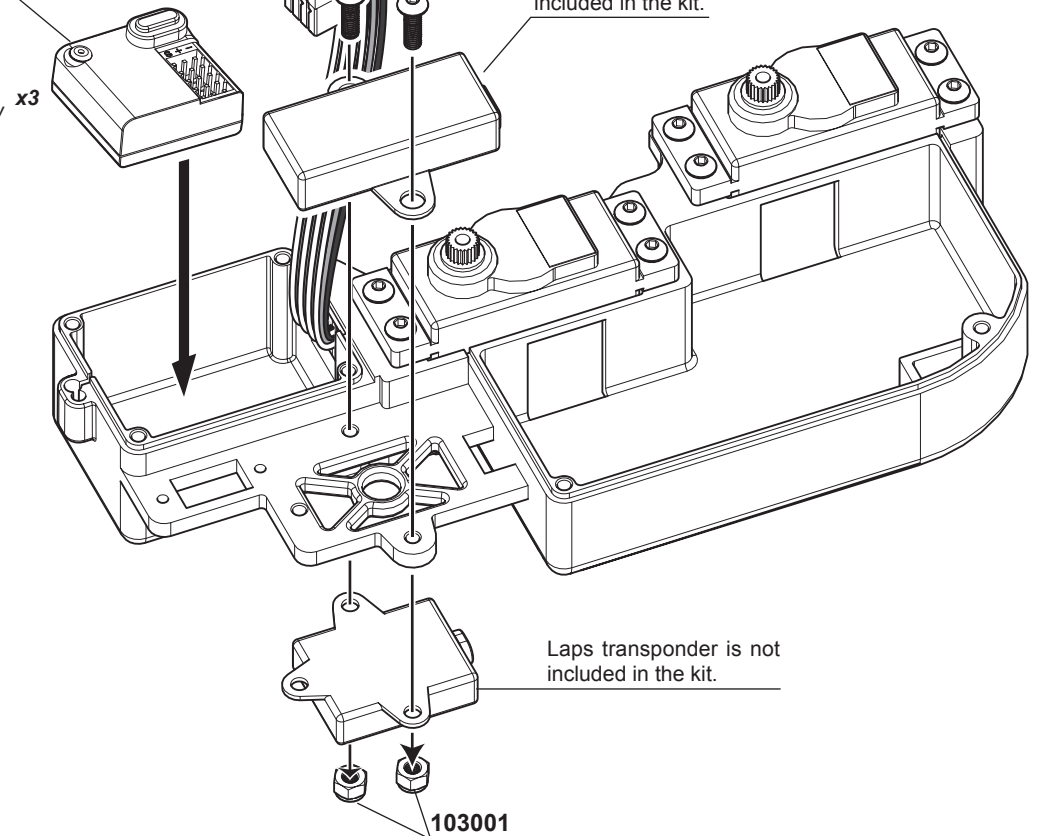



108006
M3x8mm FH/ST HEX Screw x4

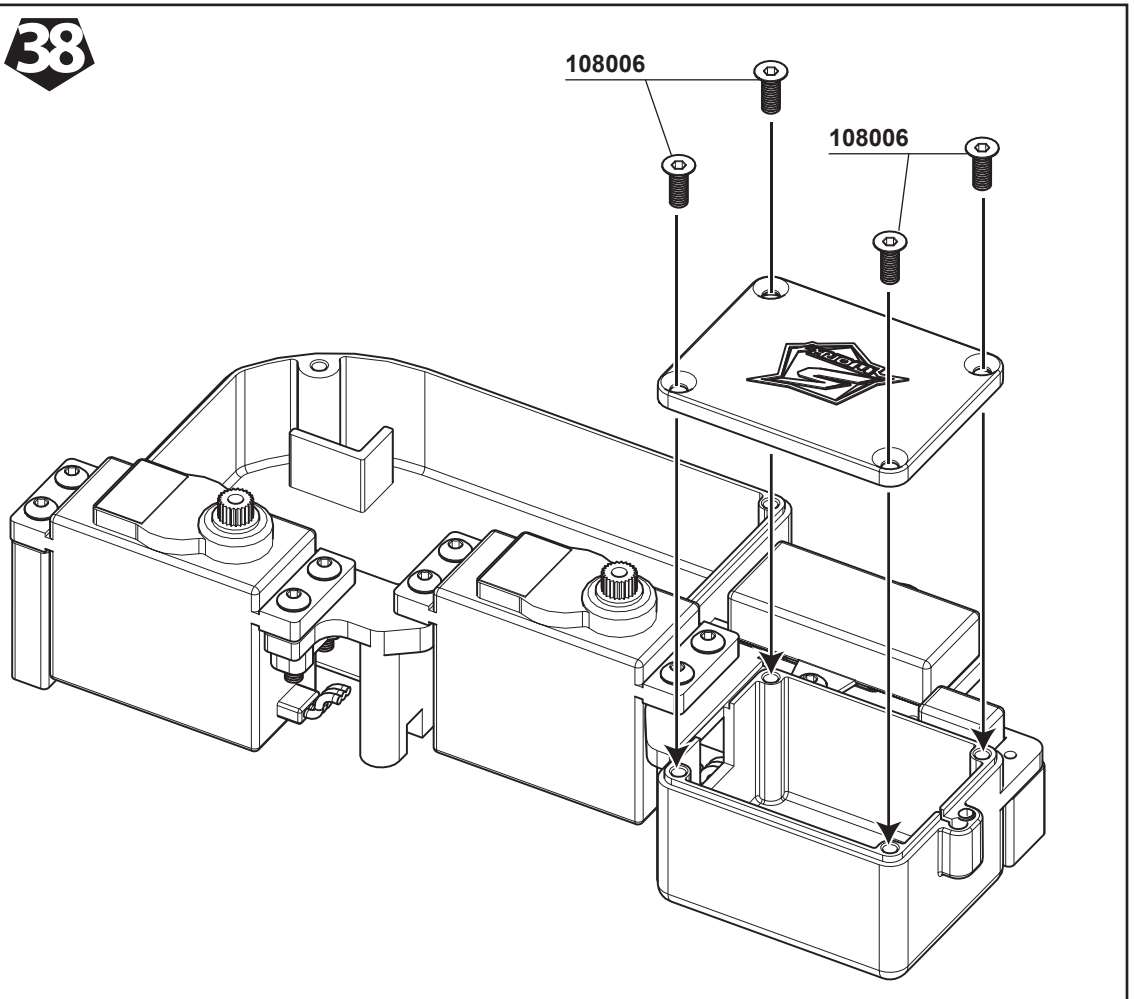

104004
M3x3mm Set Screw x1



106001
M3x8mm Hex Socket OH/TP Screw x3

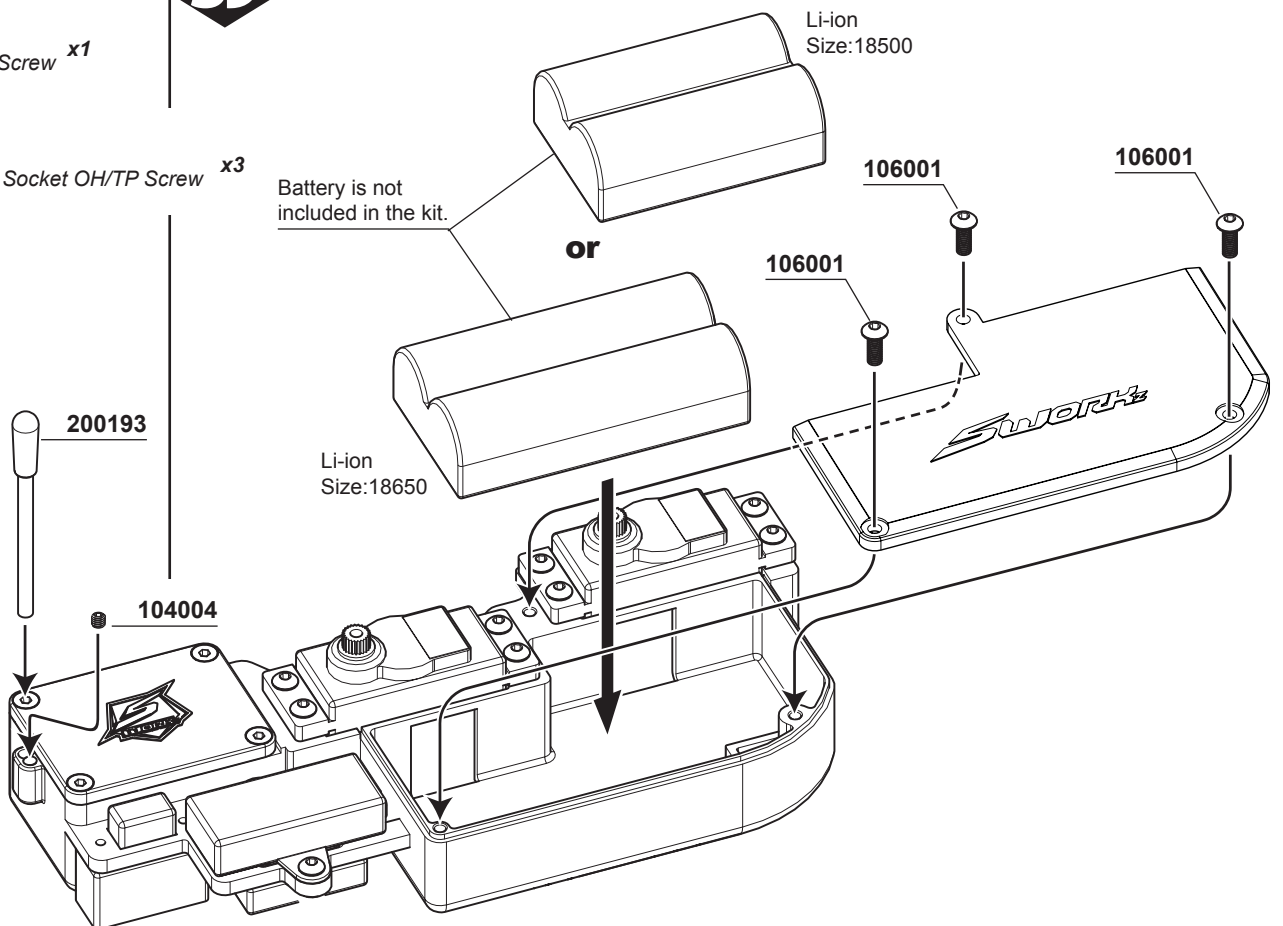

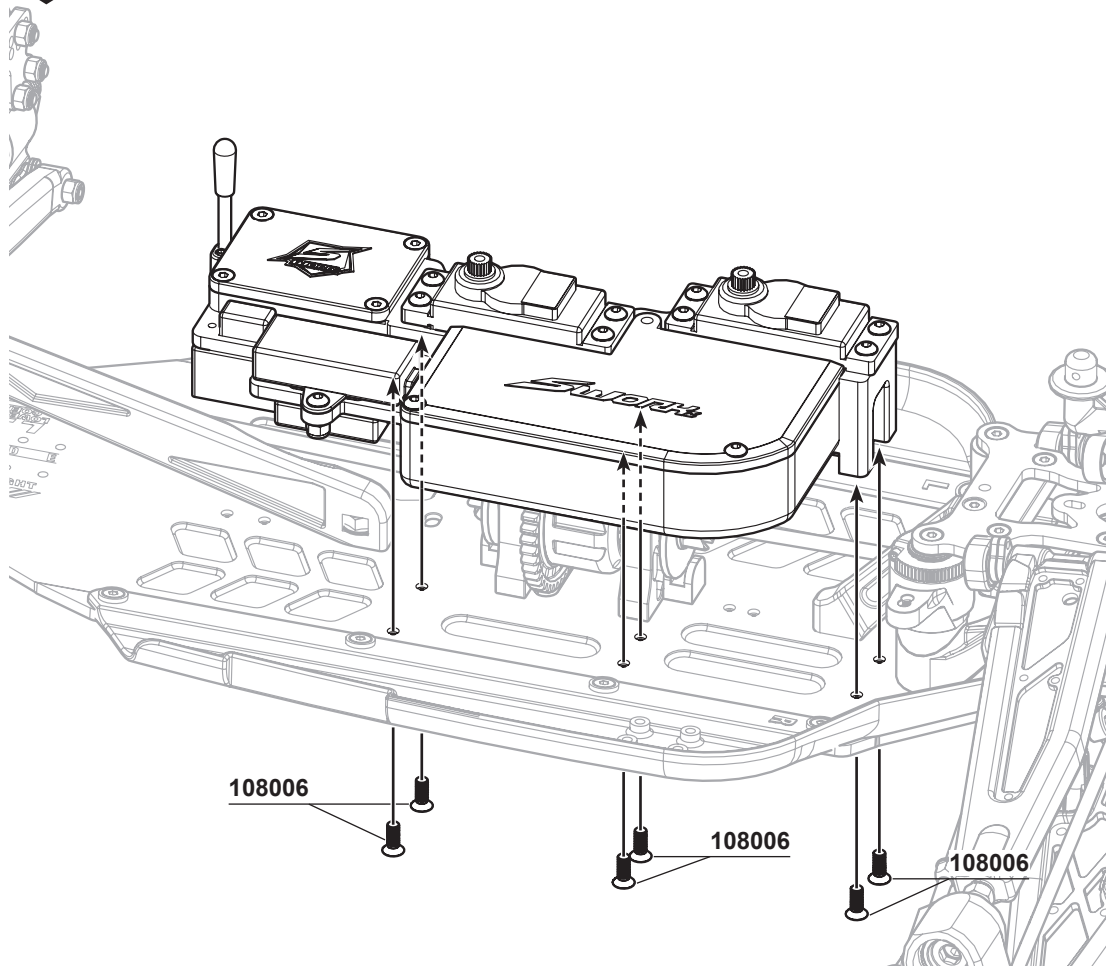

108006
M3x8mm FH/ST HEX Screw x6

108006

108006

108006

OPTION:

SW-338078-25 SWORKz Uni-Design 2-Way System Aluminum Steering Servo Horn 25T
SW-338078-23 SWORKz Uni-Design 2-Way System Aluminum Steering Servo Horn 23T



106007
M3x12mm Hex Socket OH/TP Screw (HT) x1



330155
Steering Servo Turnbuckle (M3x30mm) x1



103001
M3mm Nut Lock x1

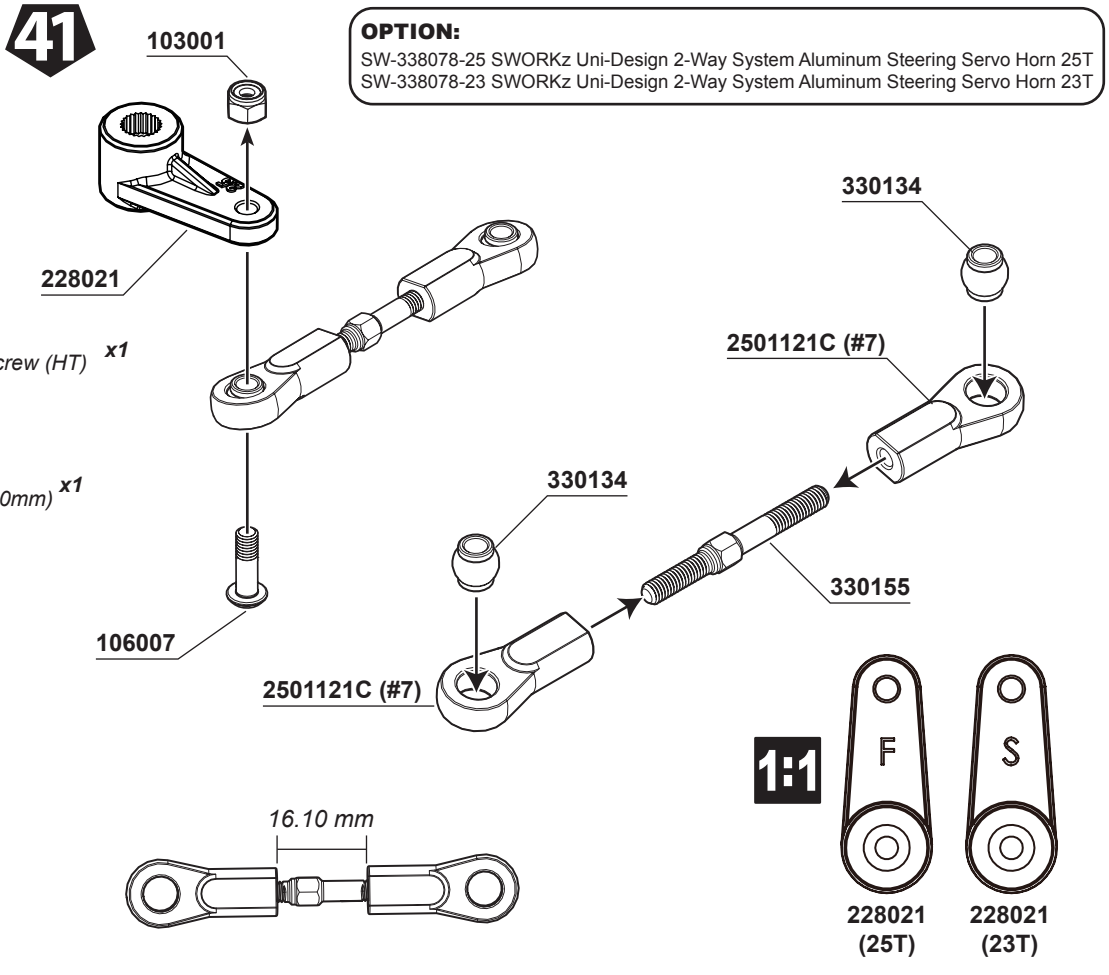

103001

228021

330134

2501121C (#7)

330134

330155

106007

2501121C (#7)

16.10 mm

1:1

F

S

228021 (25T)

228021 (23T)

BAG G

42



105001
M3x8mm Cap Screw x1



106007
M3x12mm Hex Socket OH/TP Screw (HT) x1



103001
M3 Nut Lock x1

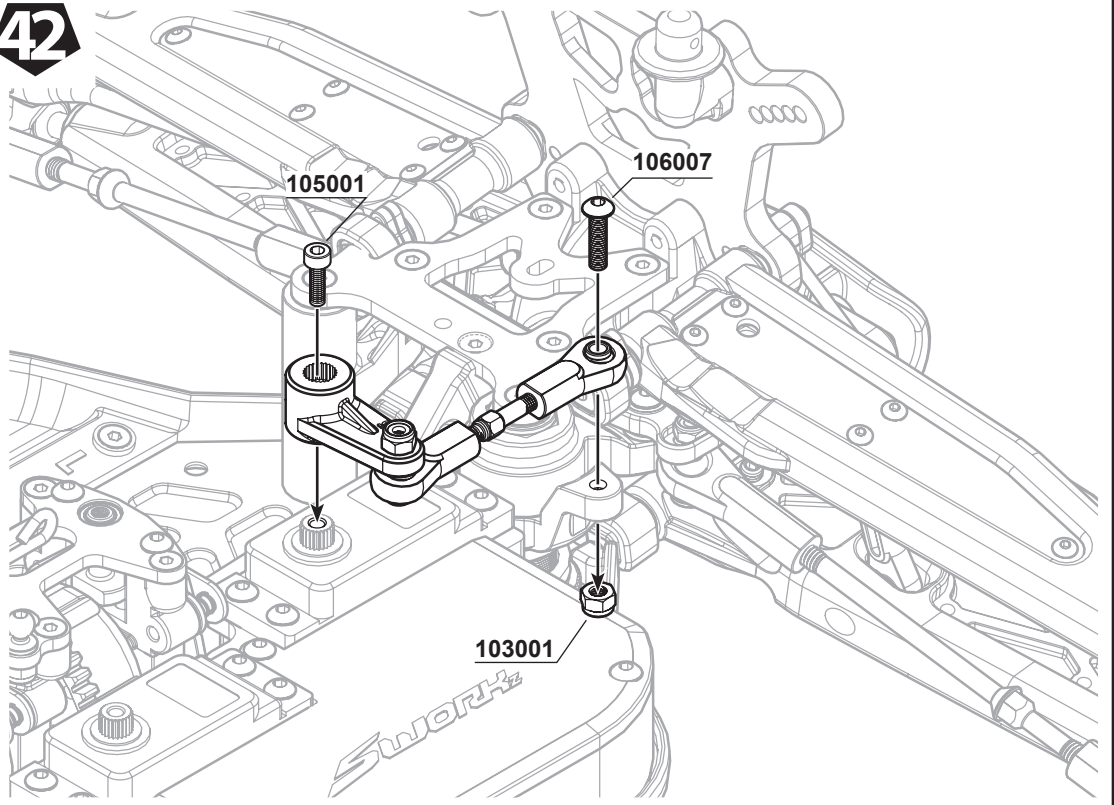

BAG H

43



108006
M2.5x5mm FH/ST HEX Screw x2



106020
M2.5x5mm Hex Socket OH/TP Screw x3



106002
M3x10mm Hex Socket OH/TP Screw x3

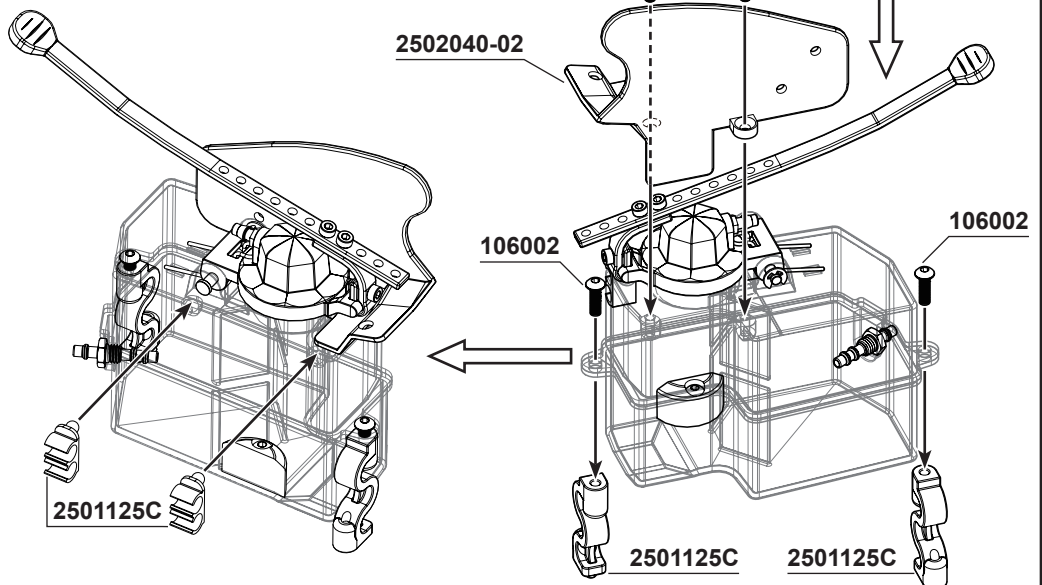
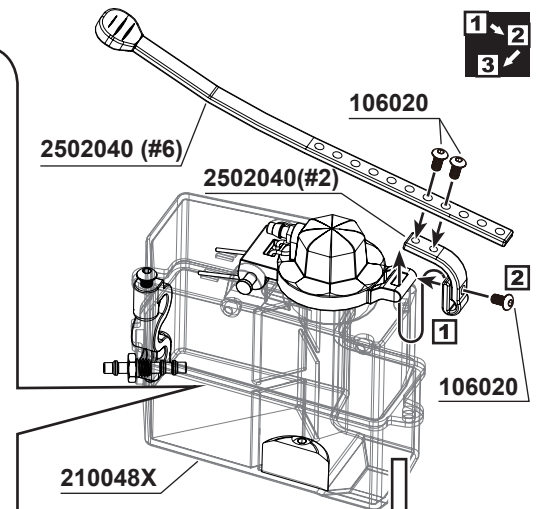
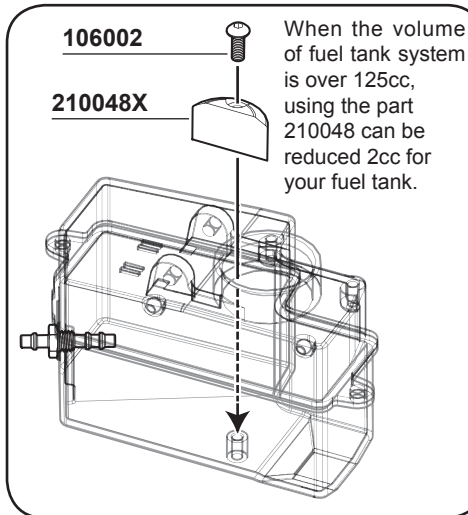

BAG H

44



108003
M3x10mm FH/ST HEX Screw x2

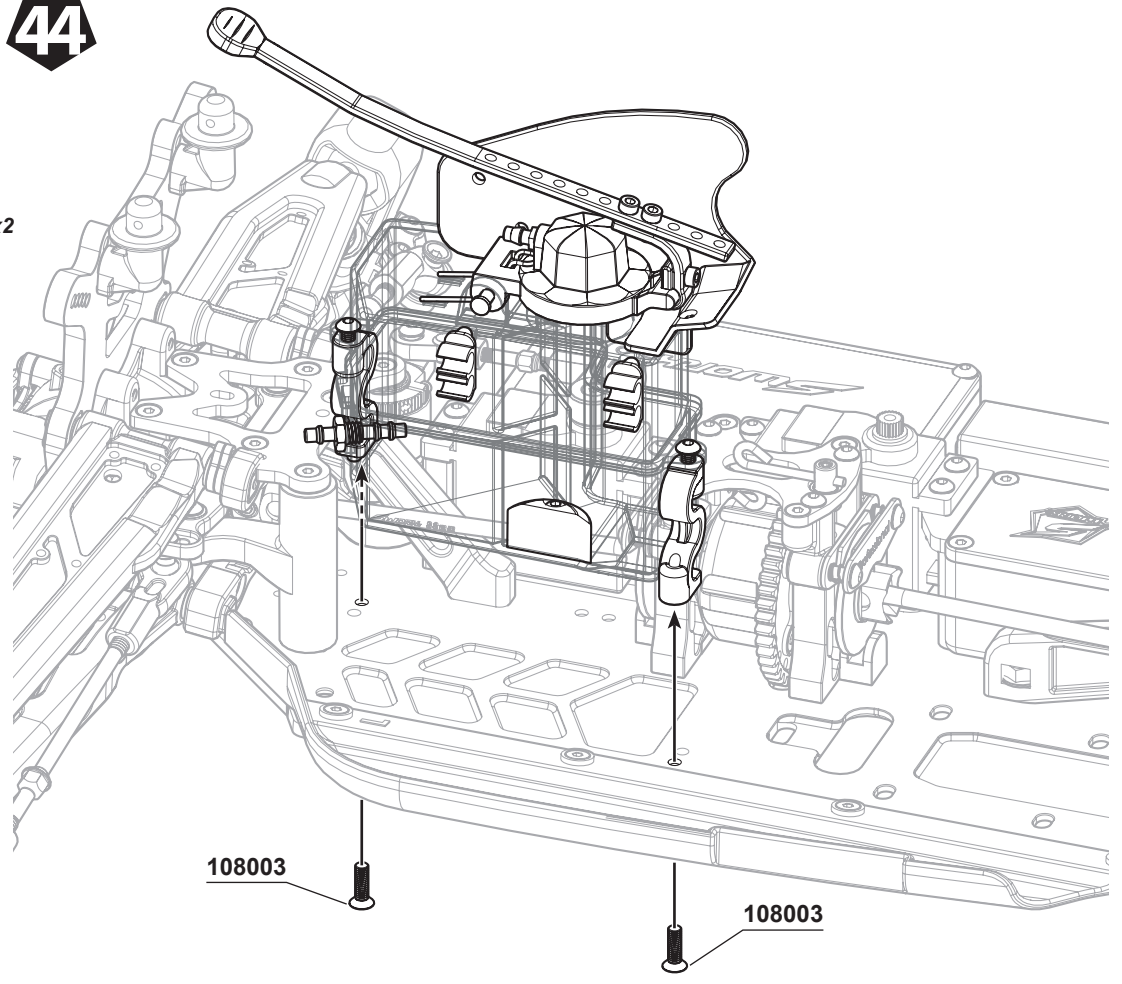

BAG I

45





105005
M3x12mm Cap Screw x4

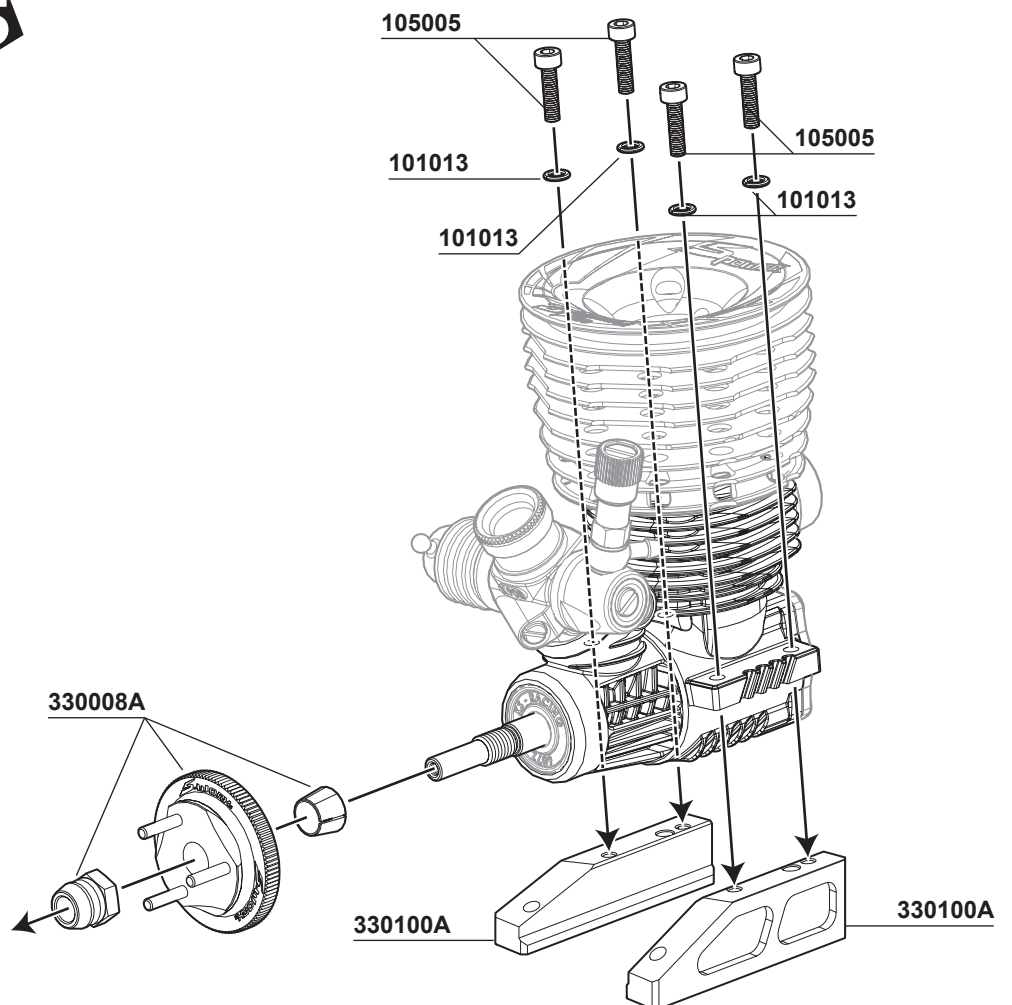

101013
3mm Spring Washer x4



 **105001**
M3x8mm Cap Screw x1

 **101021**
M3x8xT0.8mm x1

 **101015**
M5x8xT0.4mm x2

 **101016**
M5x8xT0.8mm x3

116010R
Ball Bearing 5x10x4mm (Red Rubber Case) x2

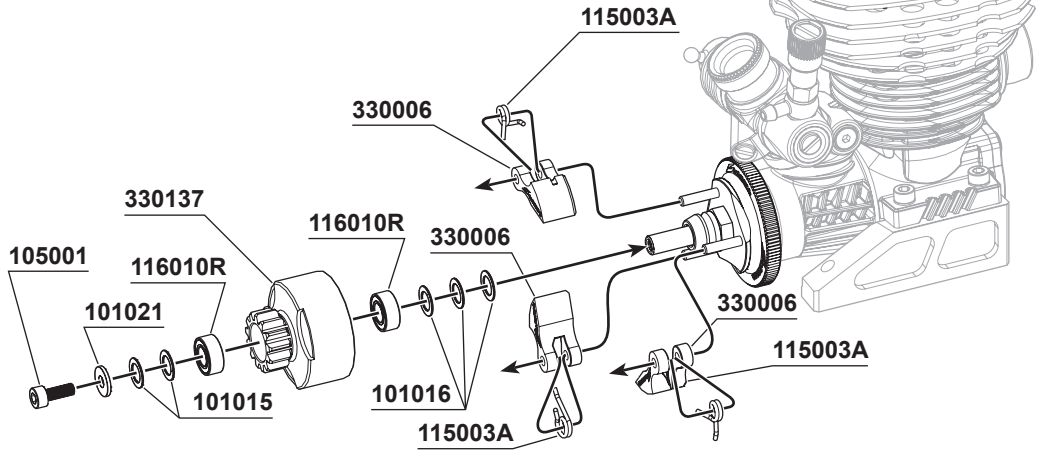

 **105007A**
M4x8mm I-Head Screw x4

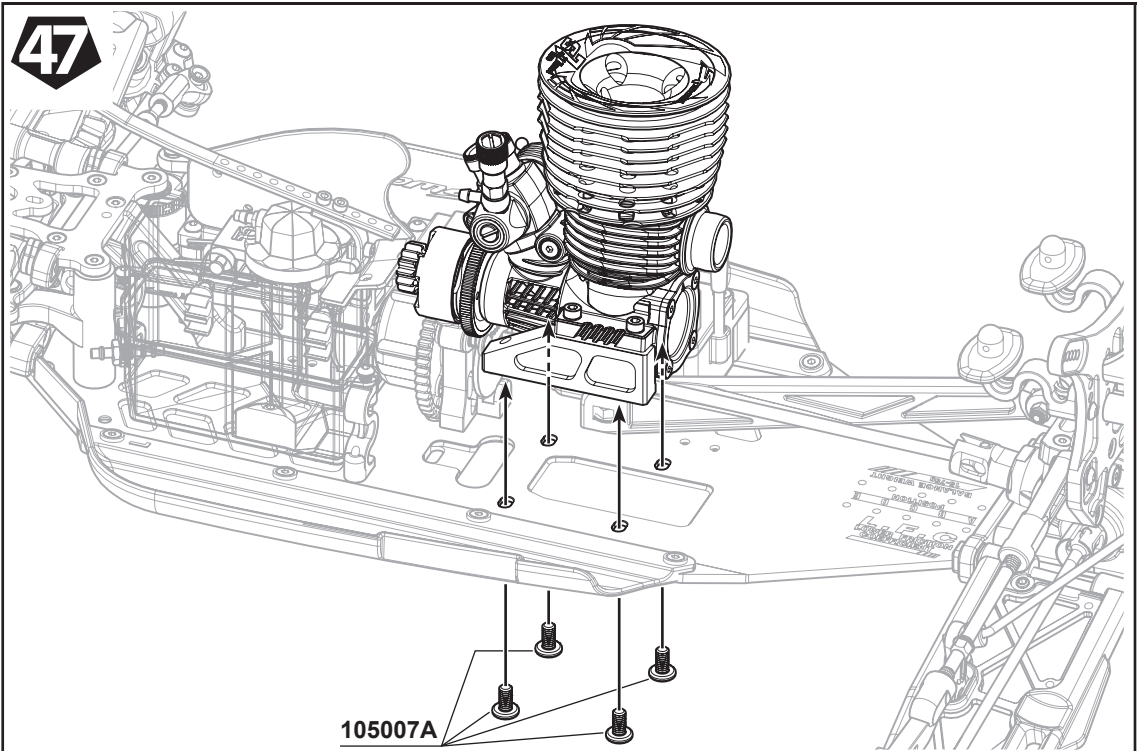

 **104011**
M4x4mm Set Screw (Flat Bottom) x2

 **108013**
M4x8mm FH/ST HEX Screw x1

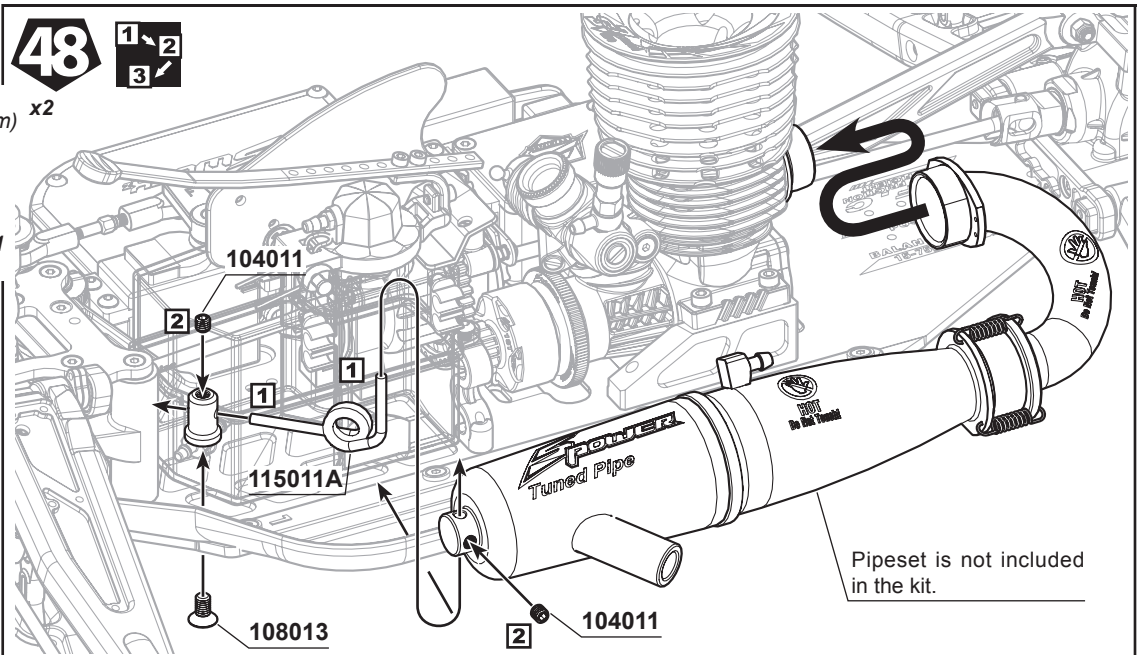

104004
M3x3mm Set Screw x6



106007
M3x12mm Hex Socket OH/TP Screw(HT) x1

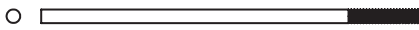

210018
Throttle Rod 50mm x1

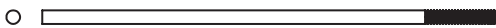

210018
Throttle Rod 60mm x2



330157A
Brake Adjuster Knob x2



106020
M2.5x5mm Hex Socket OH/TP Screw x3



108006
M3x8mm FH/ST HEX Screw x1



330156A
Adjuster Knob x4



115015
Brake Spring x2



210018
Throttle Rod Spring x1



104002
M3X10mm Set Screw x1



330299
SWORKz 1/10 Linkage Ball Stud (D5mm x L7mm) x2



103001
M3 Nut Lock x1

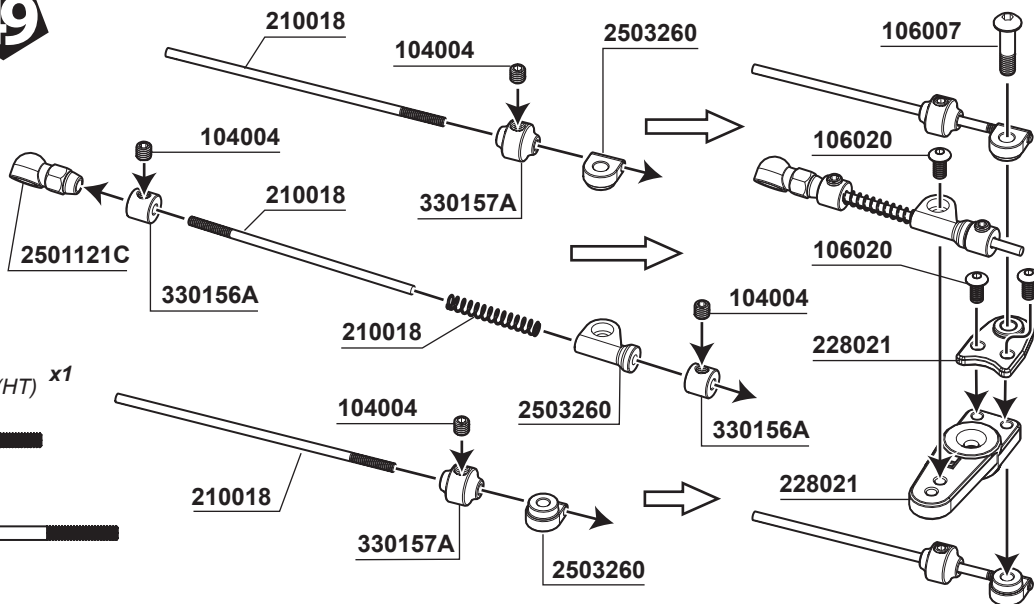

50



OPTION:

SW-338079-25 SWORKz Uni-Design Aluminum Throttle Servo Horn 25T
SW-338079-23 SWORKz Uni-Design Aluminum Throttle Servo Horn 23T

104004

330156A

210018

2503260

224007L3.5-6

104002

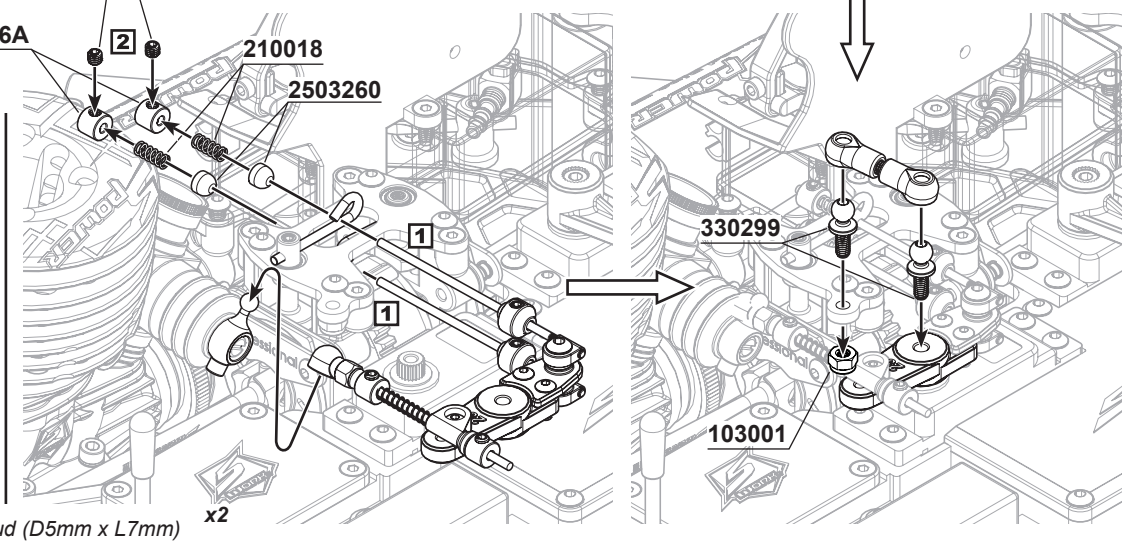

51

Linkage Adjustment

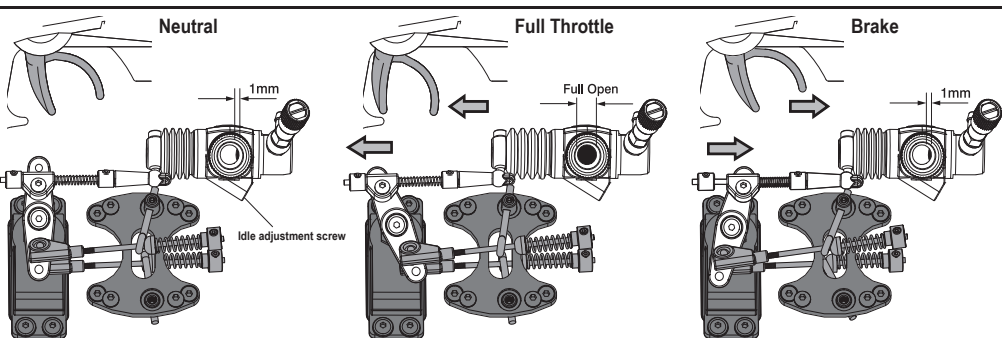

※ Turn on the transmitter and receiver. Set the throttle servo trim in neutral. Adjust the idle adjustment screw to make the carburettor opening no more than 1mm. Adjust the position of servo horn. Check that it operates smoothly without making the operation of the other parts difficult. Make sure the brake does not work in this setting.

※ Adjust the servo horn to fully open the carburettor. Change the position of servo horn if the carburettor is not fully open or opens too much. If your transmitter has a function to adjust throttle end points, make an adjustment this way.

※ Adjust the position of servo horn to make the brakes function. Make sure the brakes do not work when the servo trim is in neutral.

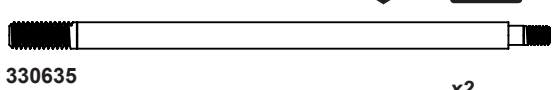

330635
S350 New BBS System +5.5mm Shock Shaft (L) x2

330636
S350 New BBS System +1.3mm Shock Shaft (S) x2

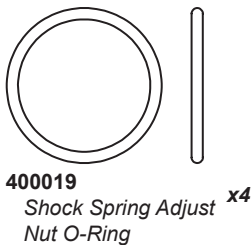
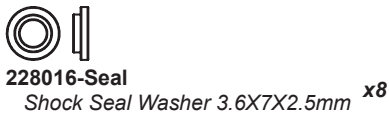
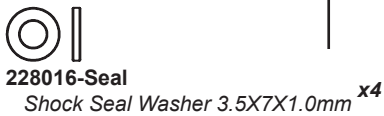

Front 330634(S)
Rear 330633(L)

400020

400006

228016-Seal

330557

228006A

Front 400010(S)
Rear 400009(L)

101046 103004
Front 330636(S)
Rear 330635(L)

Front 228016-1.2-8
Rear 228016-1.3-8

Standard bladder shock cap assembly note

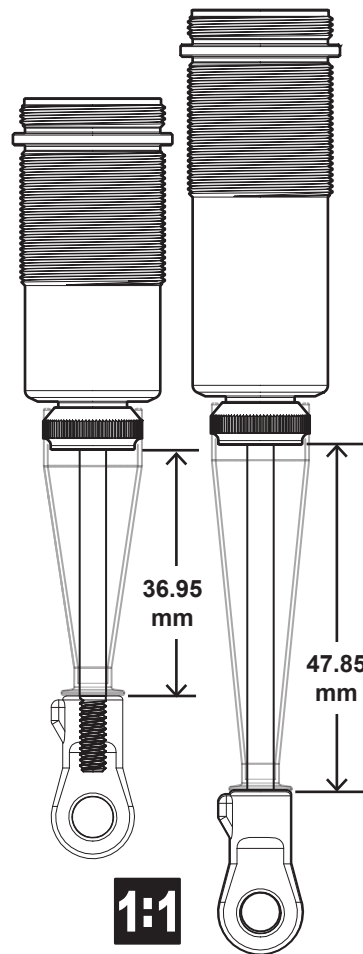
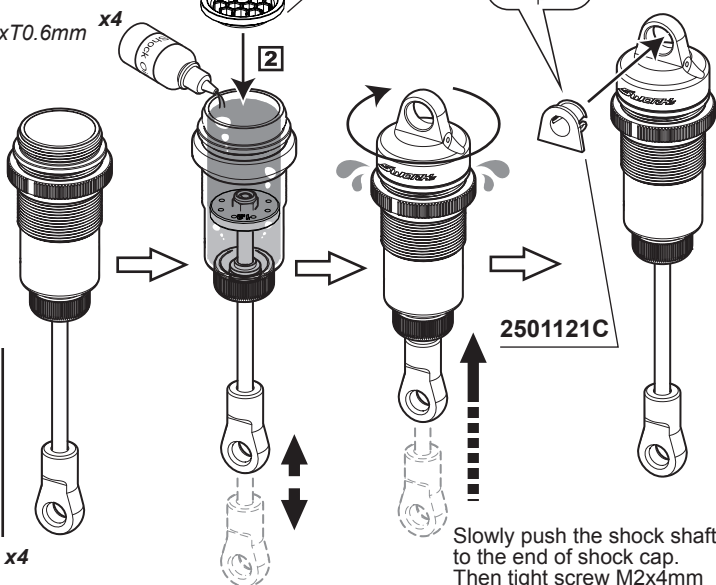
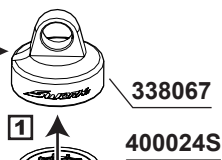

115170
S35 Series Competition Black Line Rear Shock Spring (RM3-Dot)(80X1.6X10.0) x2



115168
S35-4 Black Competition Front Shock Spring (US3-Dot)(62X1.6X7.75) x2

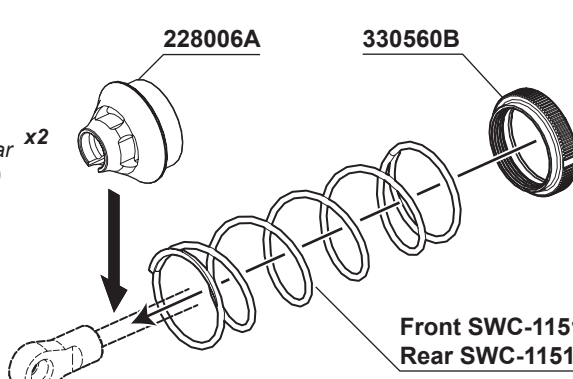

Front SWC-115168
Rear SWC-115170

330134

400019



105006A
M3x28mm Cap Screw x2



105013A
M3x25mm Cap Screw x2

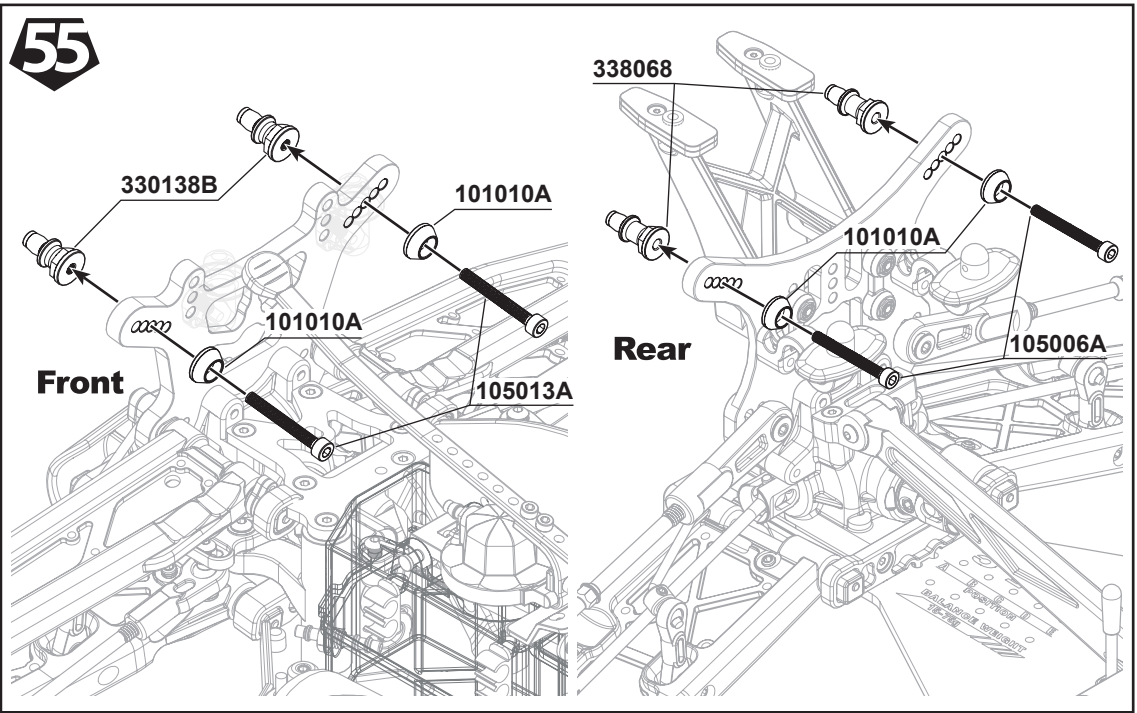

103003A
Flange M3 Nut Lock x4

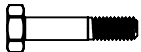

330243
SWORKz 3x16mm Shock Hex Screw Clockwise x2

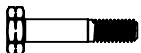

330243
SWORKz 3x16mm Shock Hex Screw Anti-Clockwise x2

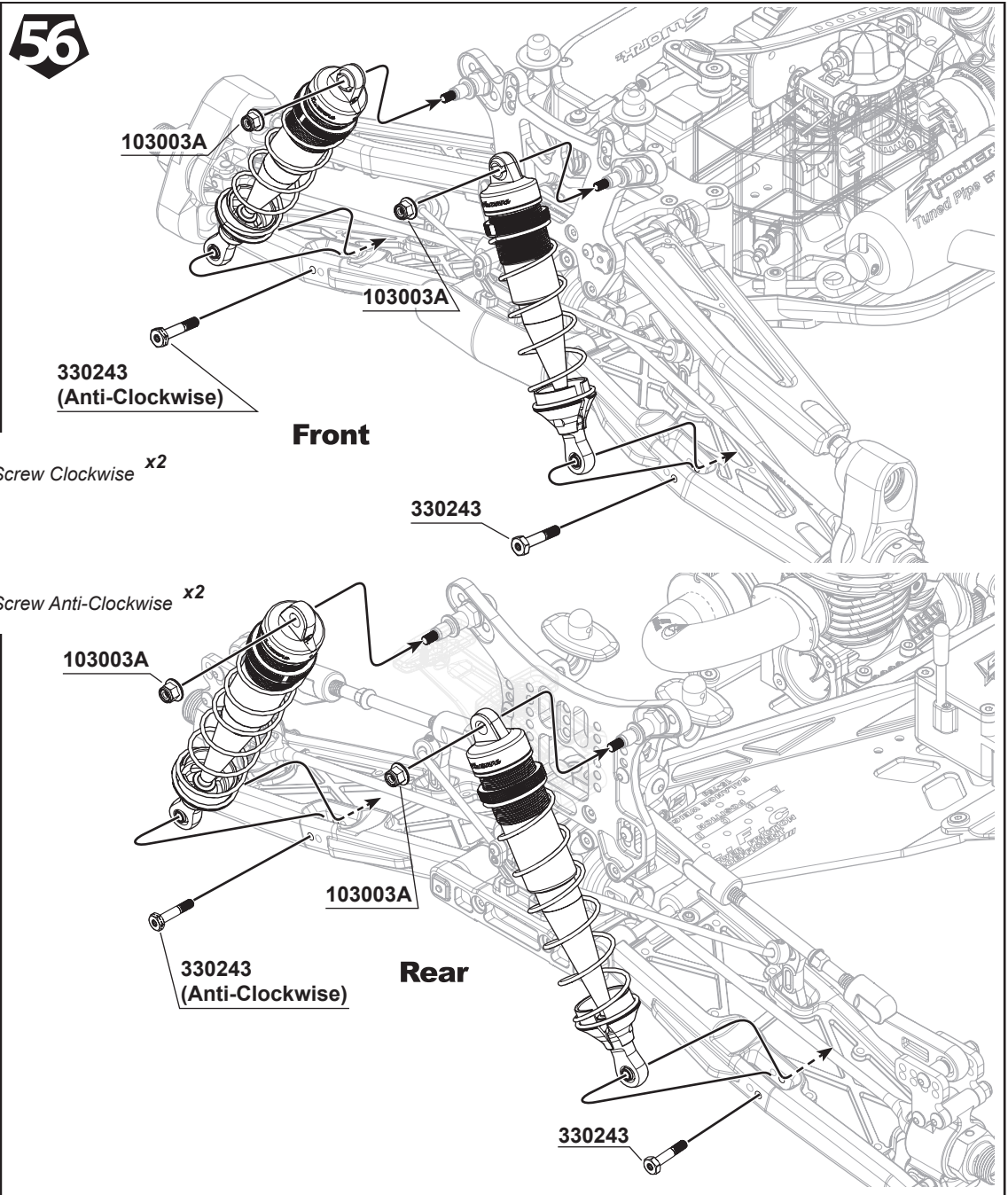



108006
M3x8mm FH/ST HEX Screw x1

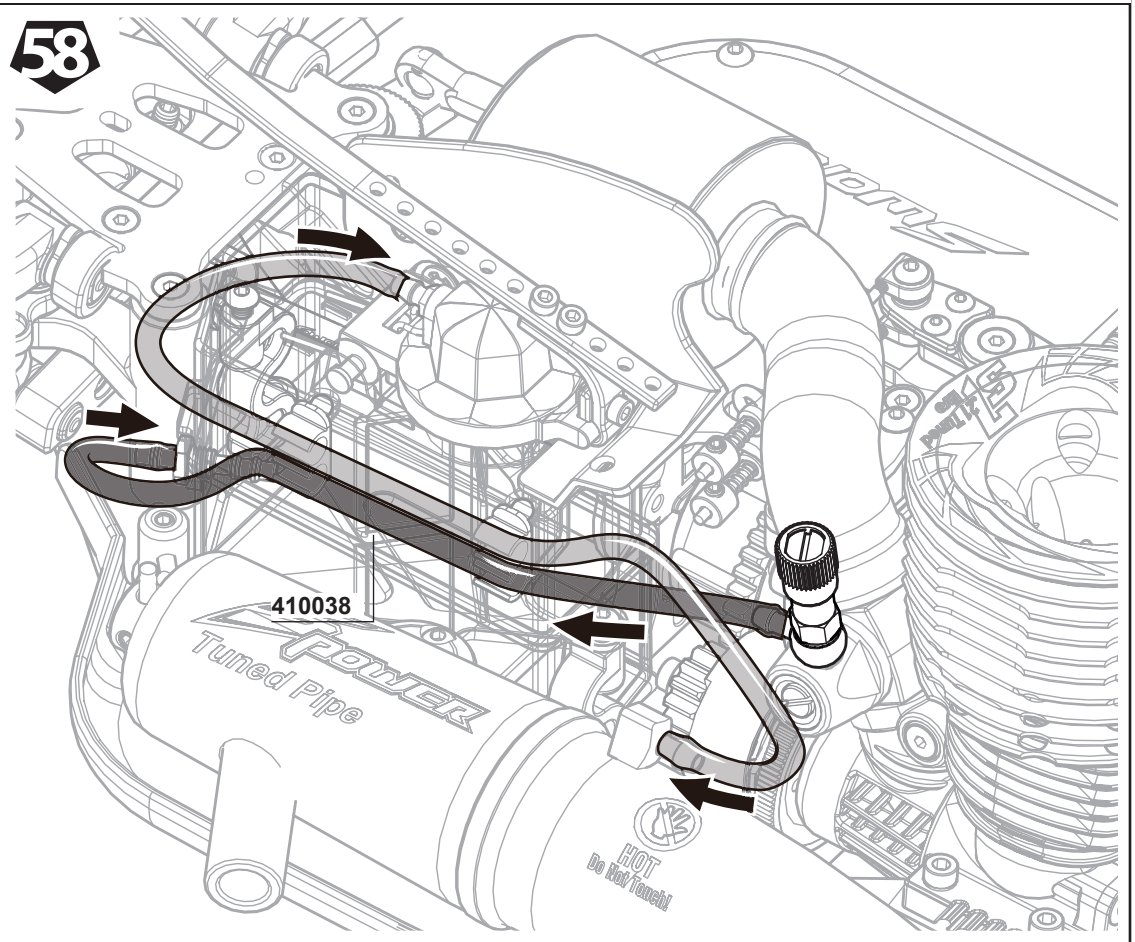
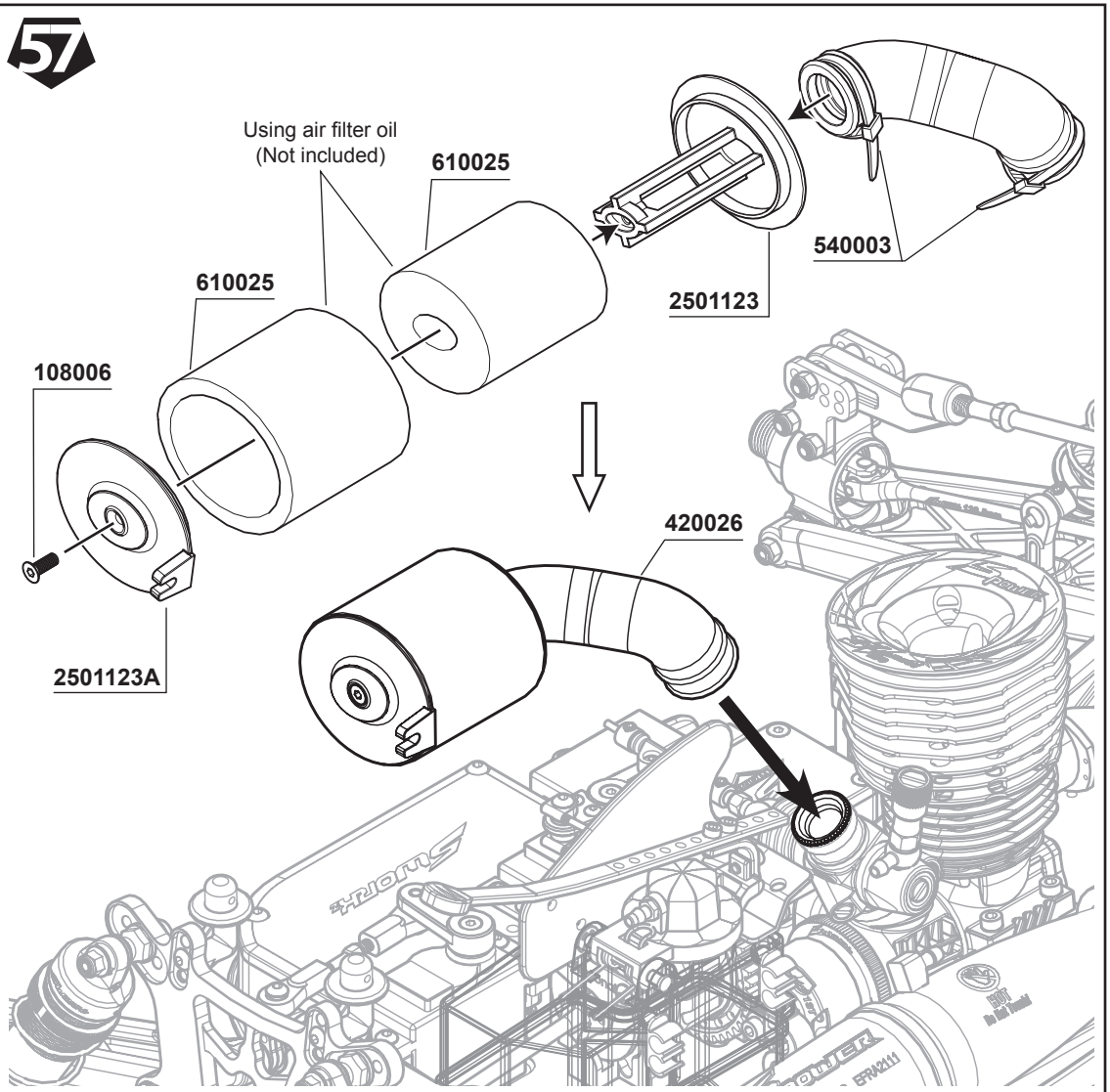

Attention!

The S35-T2 body post positions are different as of the body shell's. Please check the "RED DOTs" marked on the body shell. Or follow the manual's instructions for the actual body posts positions.

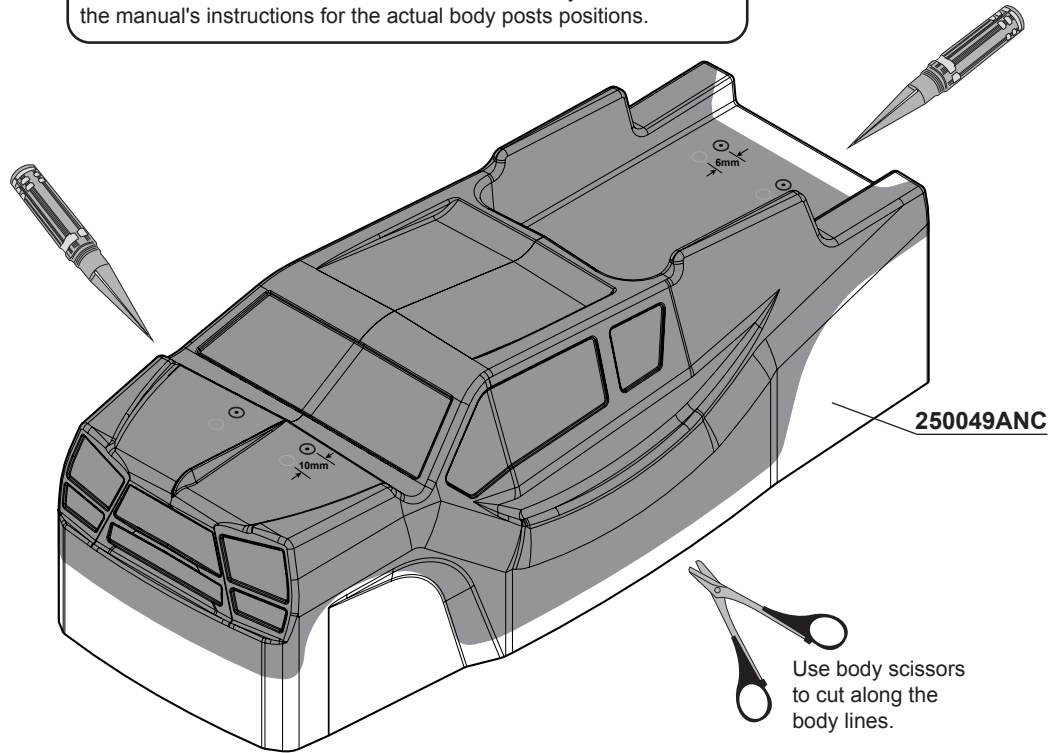

Use water/washing solution to clean body.

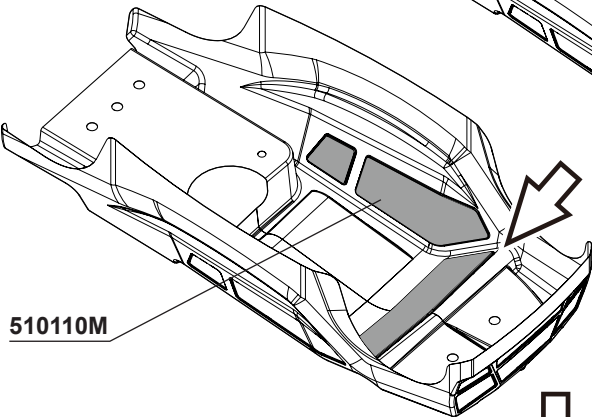
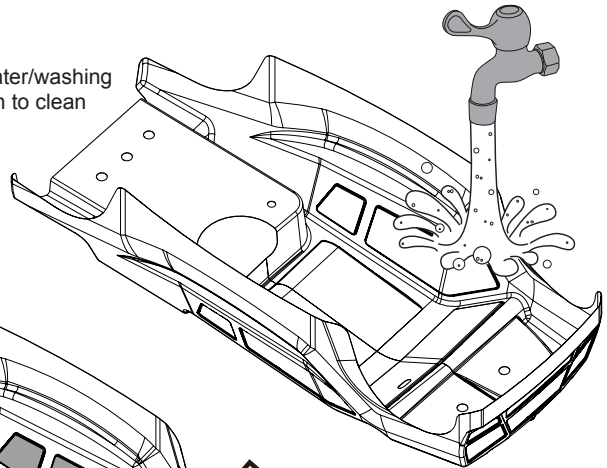

Apply window masks as shown.

510110M

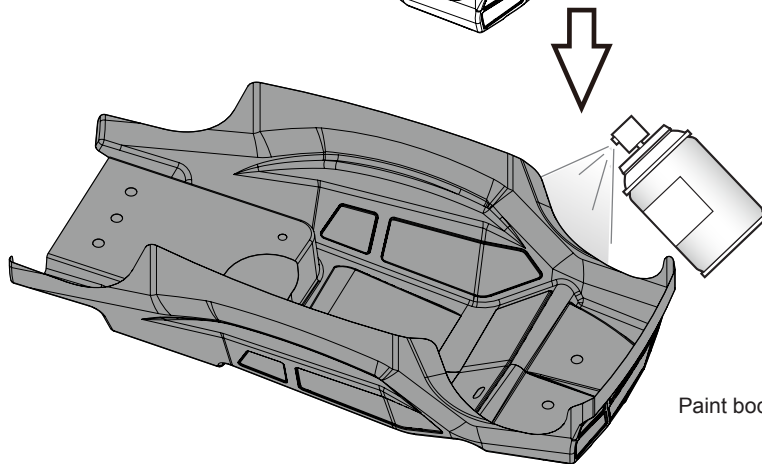

Paint body.

61



105005
M3x12mm Cap Screw x2



106025
M2.5x8mm Hex Socket OH/TP Screw x5

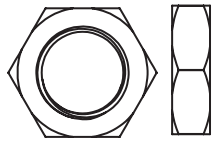
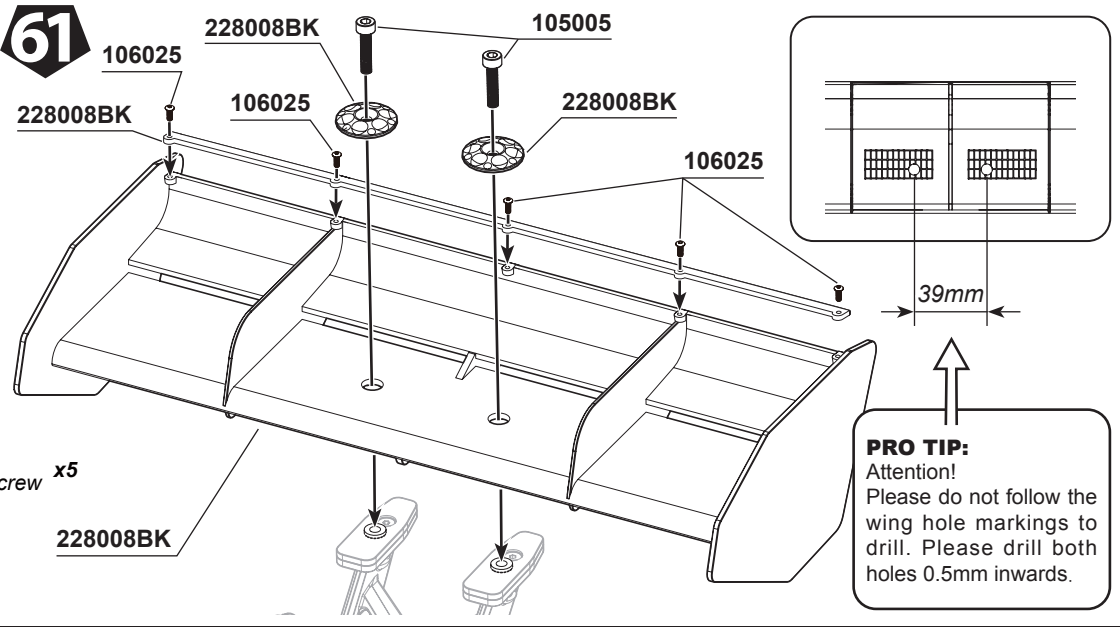

330122A
Wheel Nut x4

62

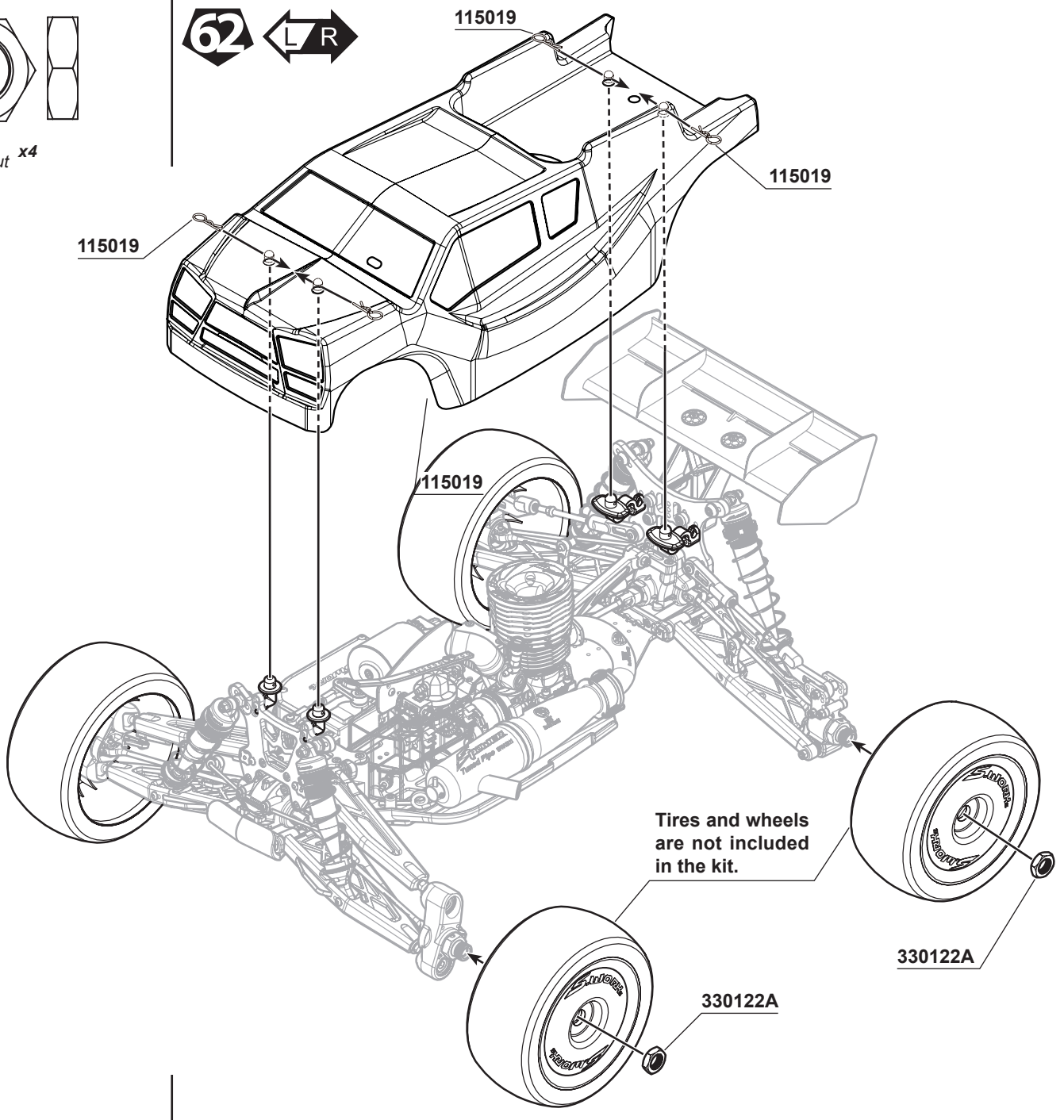

Name: _____
 Date: _____
 Track: _____

Diff. Oil
 Front: _____
 Center: _____
 Rear: _____

Track Conditions
 Size: Open Med. Tight
 Traction: High Med. Low
 Surface: Smooth Med. Bumpy

Tire
 Front Type: _____
 Front Foam: _____
 Rear Type: _____
 Rear Foam: _____

Engine
 Type: _____ Muffler: _____
 Gasket: _____ mm Fuel: _____
 Plug: _____

Clutch
 Clutch shoes: _____
 Spring: _____ mm
 Clutch bell / Spur gear: _____

Front Suspension

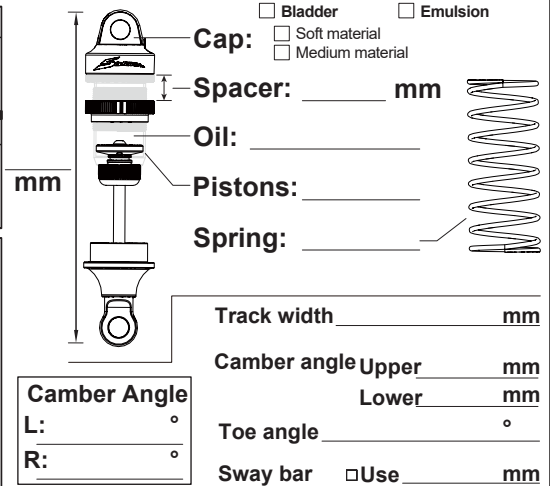
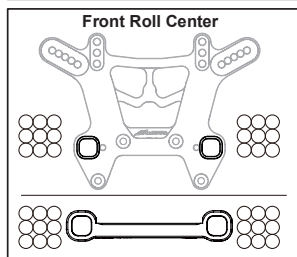
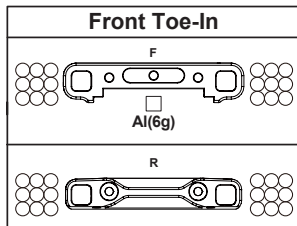
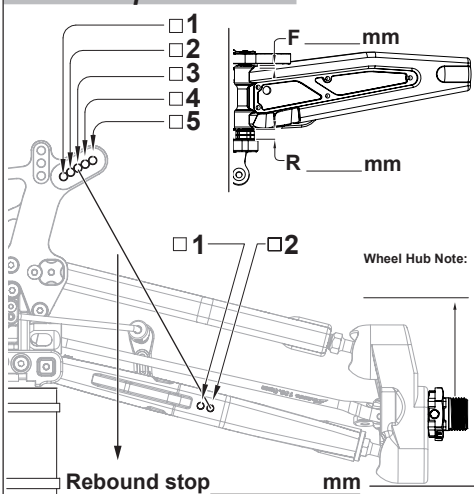

Camber Angle
 L: _____ °
 R: _____ °

Rear Suspension

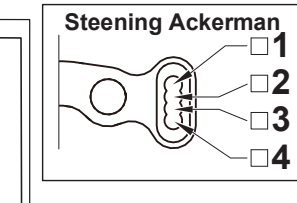
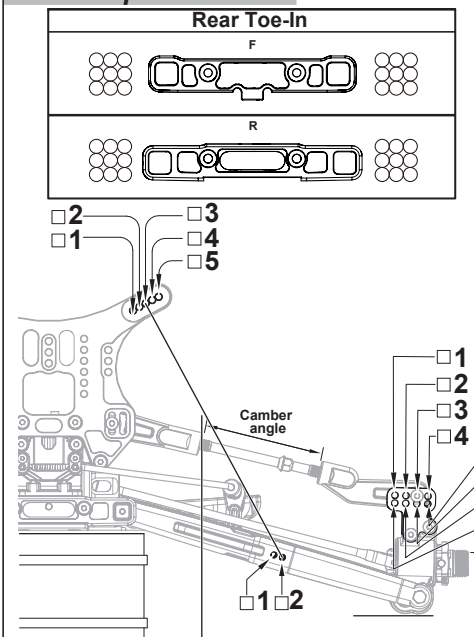

Body: _____
Wing: _____

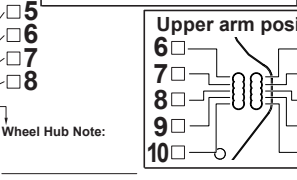
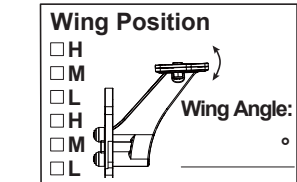

Rear Ride Height
 Chassis _____ mm
 Ground _____ mm

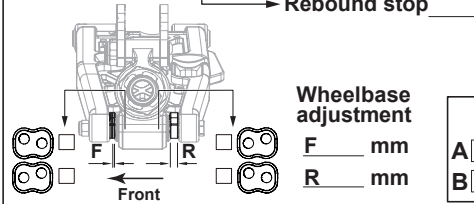
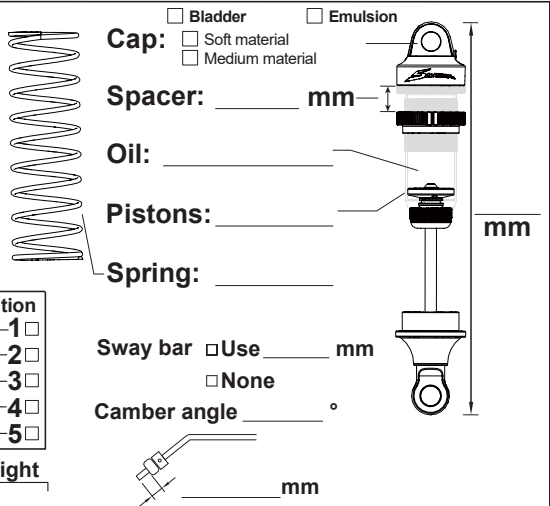
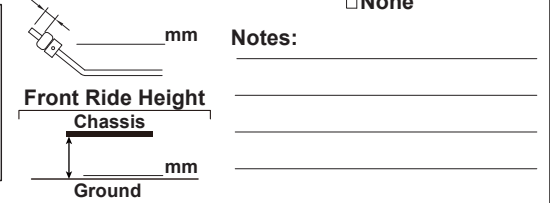

A Brass(15g) x _____
 B Brass(15g) x _____
 C Brass(15g) x _____
 D Brass(15g) x _____
 E Brass(15g) x _____

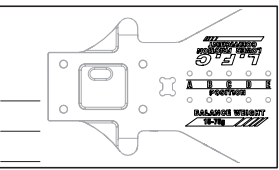

Option Parts List

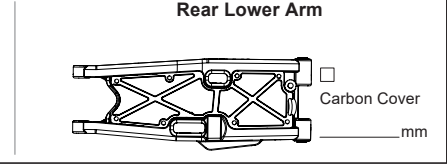
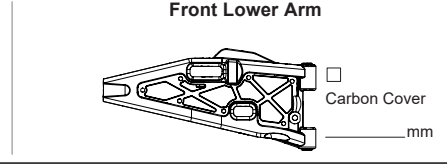
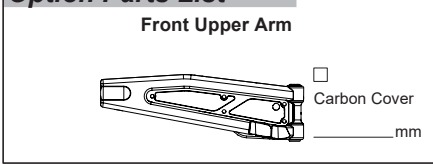

Name: _____
 Date: _____
 Track: _____

Diff. Oil
 Front: _____
 Center: _____
 Rear: _____

Track Conditions
 Size: Open Med. Tight
 Traction: High Med. Low
 Surface: Smooth Med. Bumpy

Tire
 Front Type: _____
 Front Foam: _____
 Rear Type: _____
 Rear Foam: _____

Engine
 Type: _____ Muffler: _____
 Gasket: _____ mm Fuel: _____
 Plug: _____

Clutch
 Clutch shoes: _____
 Spring: _____ mm
 Clutch bell / Spur gear: _____

Front Suspension

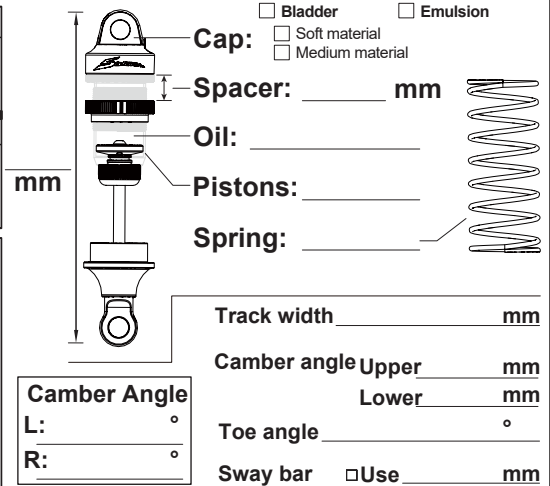
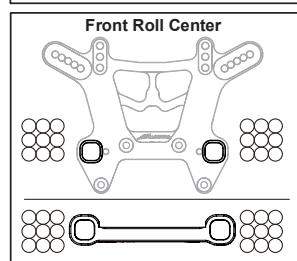
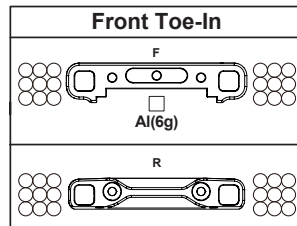
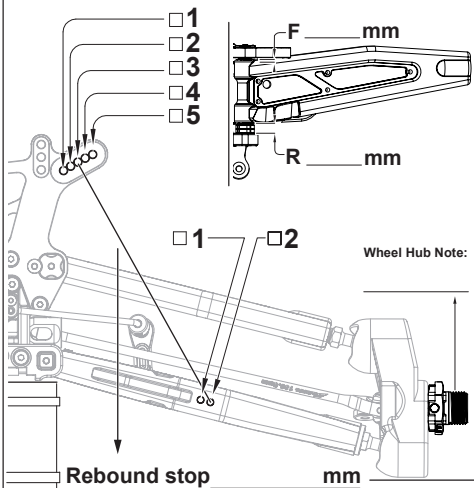

Rear Suspension

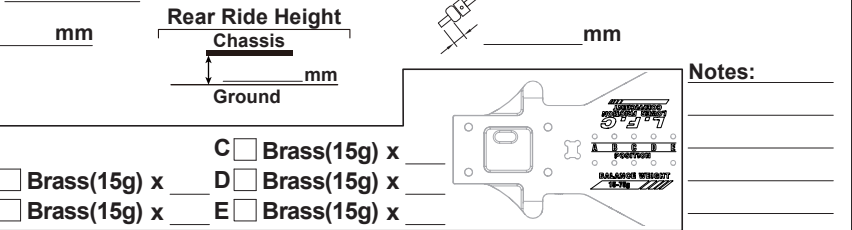
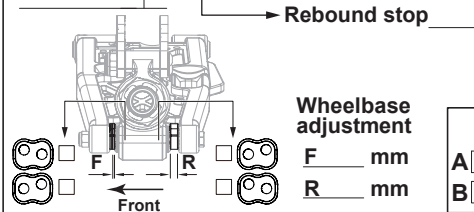
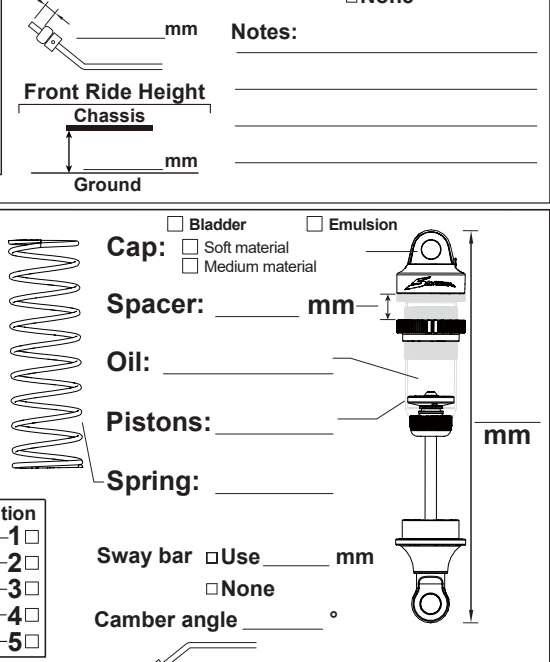
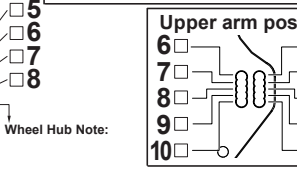
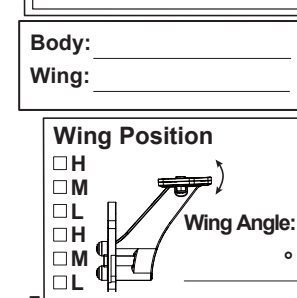
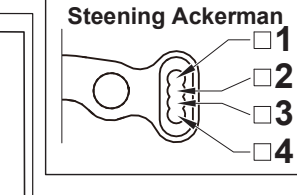
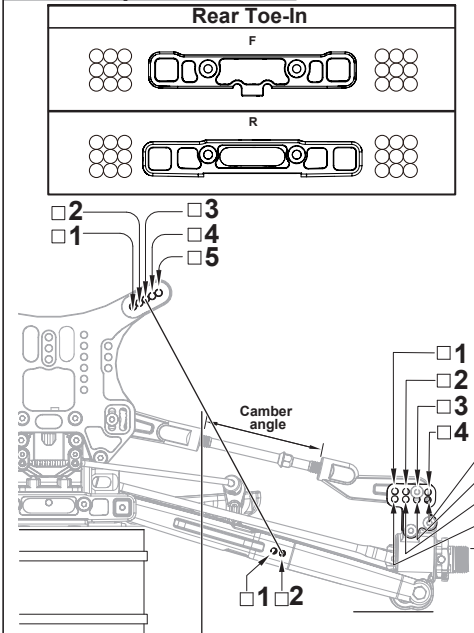

Option Parts List

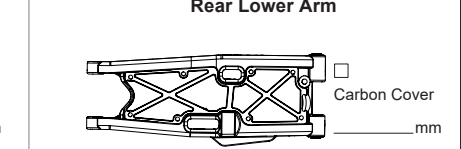
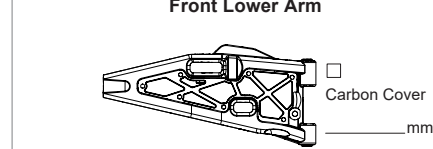
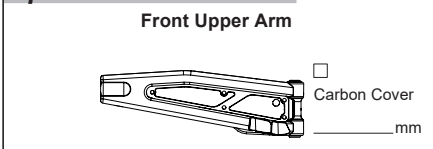

Name: S35-T2 EVO
Date: 2024
Track: Basic Set Up

Diff. Oil
Front: 7,000
Center: 7,000
Rear: 3,000

Track Conditions
Size: Open Med. Tight
Traction: High Med. Low
Surface: Smooth Med. Bumpy

Tire
Front Type: Option (Tpro) **Rear Type:** Option (Tpro)
Foam: Option (Tpro) **Foam:** Option (Tpro)

Engine
Type: Option (Spower B7 PH) **Muffler:** Option (EFRA 2089)
Gasket: _____ mm **Fuel:** Option (Tpro Fuel)
Plug: Option (Spower ST-3)

Clutch
Clutch shoes: Kit Aluminum
Spring: Kit 1.0 x 3 mm
Clutch bell / Spur gear: Kit 13/48

Front Suspension

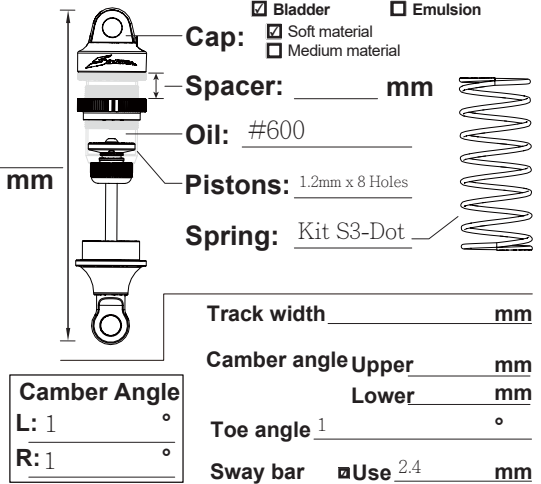
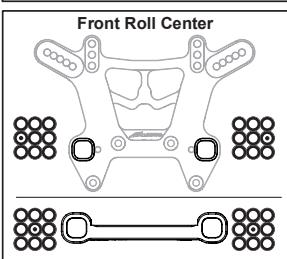
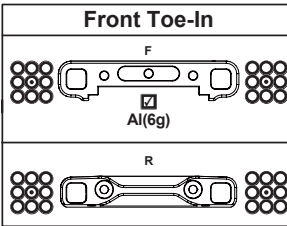
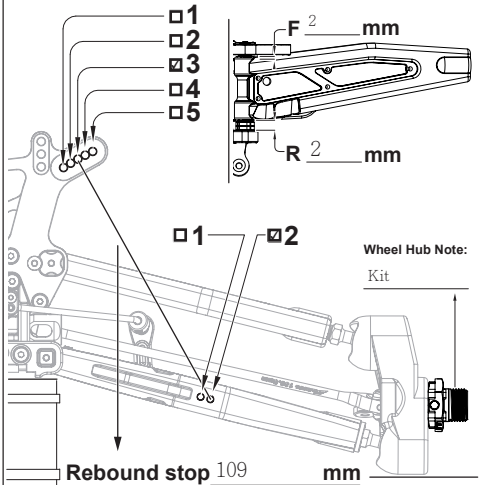

Rear Suspension

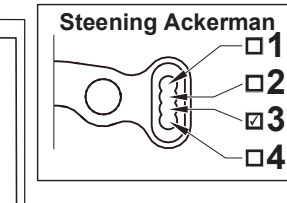
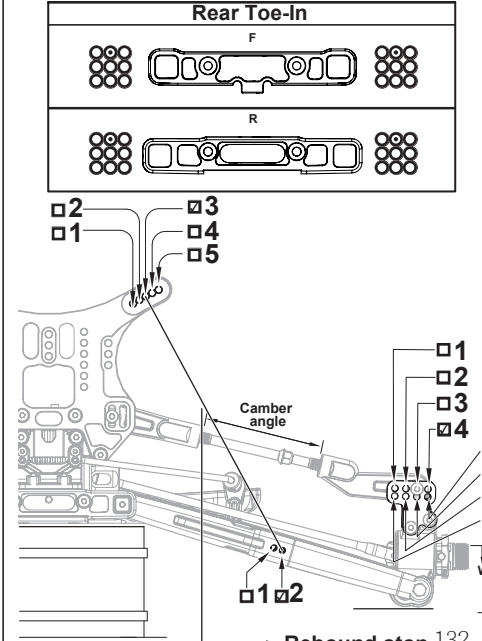

Body: Kit Rhinocero III
Wing: Kit Formula 2.0

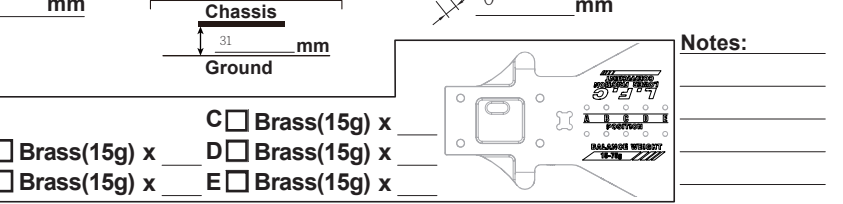
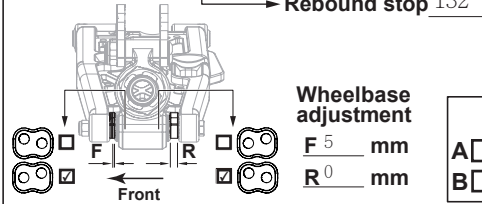
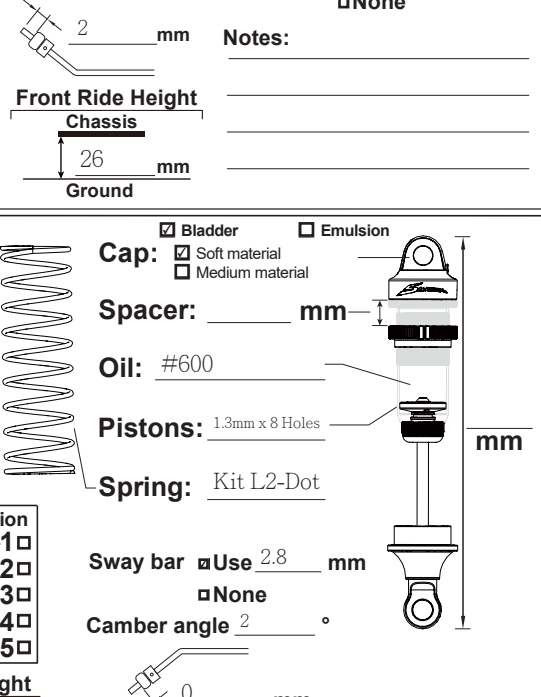
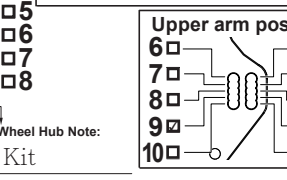
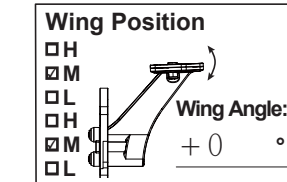

Option Parts List

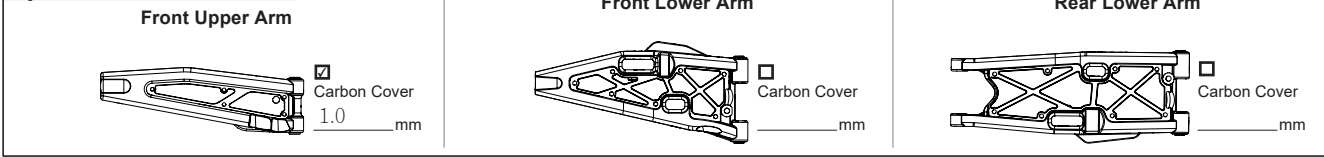

Parts No. List

Part No.	Part Name	Q'ty in Use	Item No.	Part No.	Part Name	Q'ty in Use	Item No.
210091	S35-3W Plastic Front/Rear Big Bore Diff Case	2	SW-210091	330777A	S35-4 Series Steering Linkage Ball Stud 7mm (L7)	4	SW-330777A
210079A	S35-4 Plastic Center Big Bore HET Diff Case	1	SW-210079A	330782	S35-3 Series Rear Hub Carriers Hinge Pin	2	SW-330782
210048X	S35-T/S35-GT Tubed Floating Fuel Filter System Tank Set (150cc)	1	SW-210048X	330822	S35-T Steel Center Rear Drive Shaft 165mm	1	SW-330822
2501115	S350 Rear Lower Arm Dusty Cover with Fuel Sprinkle Guard	1	SW-2501115	338011	S35 series Pinion Gear Stopper (5x7x5.1mm)	2	SW-338011
2501124	S350 Center Diff. Mount Set	2	SW-2501124	338014	S35-3W T-7075AL Rear Lower Fully Adjustable Toe-In Block (3 degree)	1	SW-338014
2501529	S350 BX1/BR1 Rear Chassis Brace	1	SW-2501529	338025	S35-3W Bevel Gear Shaft	6	SW-338025
2501097B	S35 Series Front Bumper	1	SW-2501097B	338027	S35-3W Front/Rear Diff. Outdrive	4	SW-338027
2501121C	S35/S350 Series Ball End Set with Shock Plastic Parts	2	SW-2501121C	338028	S35-3W Center Diff. Outdrive	2	SW-338028
2501122C	S35/S350 Series Durable Setting Bellcrank Set (with Servo Horn)	1	SW-2501122C	338041	S35-3/4 Series Center HET Spur Gear (48T)	1	SW-338041
2501126A	S350/S350T Series Option Air Filter Extension Set	1	SW-2501126A	338043	S35-3/4 Series Servo Saver Nut with Screw Fixed	1	SW-338043
2502040-01	S350T Rear Plastic Chassis Brace	1	SW-2502040-01	338045	S35-T Series HET System Pinion Gear 10T	2	SW-338045
2502040-02	S350T Body Mount with Fuel Tank Ring-pull	1	SW-2502040-02	338046	S35-T Series HET System Crown Gear 46T	2	SW-338046
2503260	S353 Series Plastic Inserts Set	1	SW-2503260	338048	S35-4 Series Servo Saver Shaft	2	SW-338048
2503261A	S35-3/GT Series Gear Box Set (Fit 5x13x4mm Ball Bearing)	2	SW-2503261A	338051	S35-4 Series T7 Aluminum Steering Knuckle Plate (R=L)	2	SW-338051
2503262	S35-3 Nitro Buggy Radio Tray Set	1	SW-2503262	338052	S35-4 Series T7 Aluminum Setting Bellcrank Upper Part-A (with 2Hole)	1	SW-338052
2503264A	S35-3 Series Front Steering Knuckle (Type 2.0) L	1	SW-2503264A	338053	S35-4 Series T7 Aluminum Steering Plate	1	SW-338053
2503270-3	S35-3 Series Front Steering Ball Ends	2	SW-2503270-3	338056	S35-4 Series Lower Arm Hinge Pin (68.5mm)	4	SW-338056
228001	S35-4 Series Plastic Inserts Set	2	SW-228001	338057	S35-4 Series T7 Aluminum Front Upper Arm Holder	1	SW-338057
228002-1	S35-4 Series Plastic Rear Wheel Hub (R=L)	2	SW-228002-1	338058	S35-4 Series T7 Aluminum Front Lower Arm Plate (FF)	1	SW-338058
228002-2	S35 Series Plastic Front Chassis Shorty Brace	1	SW-228002-2	338059	S35-4 Series T7 Aluminum Front Lower Arm Holder (FR)	1	SW-338059
228003A	S35 Series Integrated Wing Mount Set 2.0	1	SW-228003A	338067	S35-4 Series Emulsion/Bladder 2 Ways Syatem Shock Cap	4	SW-338067
228004A	S35-4 Series Plastic Side Guard Set with Stopper	1	SW-228004A	338068	S35-4 Series T7 Aluminum Shock Stud (L)	2	SW-338068
228006	S35 Series Shock End/Body Mount/Ball Ends Set	2	SW-228006	338070B	S35 Series Rear Upper Sus. Arm Ball Stud (7.0mm Hex)	2	SW-338070B
228008BK	SWORKz 1/8 Off Road Formula 2.0 Race Wing (BK)	1	SW-228008BK	338085	S35-T2/E T7075 Aluminum Front Shock Tower	1	SW-338085
228010-F	S35-T2 Series Front Lower Arm	2	SW-228010-F	338086	S35-T2/E T7075 Aluminum Rear Shock Tower	1	SW-338086
228010-R	S35-T2 Series Rear Lower Arm	2	SW-228010-R	338087	S35-T2 Nitro T7075 Aluminum Lightened Main Chassis	1	SW-338087
228011	S35-T2 Series Front Upper Arm	2	SW-228011	338114	S35-4 Series T7075 Aluminum Intensity Rear Front Lower Suspension Plate	1	SW-3380114
210058	S350 New BBS System Shock Seal Washer 3.6X7X2.5mm	8	SW-210058	340016	S35-4 Series Pro-composite Carbon Rear Wheel Hub Adjust Plate (R=L)	4	SW-340016
210058	S350 New BBS System Shock Seal Washer 3.5X7X1.0mm	4	SW-210058	340017	S35-4 Series Pro-composite Carbon Steering Bellcrank Plate	1	SW-340017
210046	S350 Series LDS Universal Cross Drive Shaft Set 92.5mm (1pc)	4	SW-210046	340028-10	S35-T2 Pro-composite Carbon Front Upper Arm Cover (1.0mm)(2pc)	2	SW-340028-10
210043	S350 Professional Matel Brake Calipers 2.0 A Side	2	SW-210043	400002	O-ring S5 4.8X1.5	6	SW-400002
210043	S350 Professional Matel Brake Calipers 2.0 B Side	2	SW-210043	400005	Shock Spring Adjust Nut O-Ring	4	SW-400005
210018	Brake Spring	2	SW-210018	400006	Shock Seal O-Ring	8	SW-210058
210018	Throttle Rod 50mm	1	SW-210018	400009	Shock Boot (L)	2	SW-400009
210018	Throttle Rod Spring	1	SW-210018	400010	Shock Boot (S)	2	SW-400010
210018	Brake Rod 60mm	2	SW-210018	400019	S350 New BBS System Shock Spring Adjust Nut O-Ring	4	SW-400019
200193	Antenna Tube	1	SW-200193	400020	S350 New BBS System Shock Seal O-Ring	4	SW-400020
250049ANC	S35-T2 Speed Rhinoocor III Pre-Cut Nitro Body Shell (Clean/1.5mm)	1	SW-250049ANC	400022A-S	S35 Series BBS System Pro Shock Bladder (Soft)	4	SW-40022A-S
320010	S35-3W Diff. Bevel Gear 10T	12	SW-328001	400023	S35 Series BBS System Seal O-Ring for Emulsion Shock Cap	4	SW-400023
320009	S35-3W Diff. Bevel Gear 20T	6	SW-328001	410038	Super Silicone Tube 2455x30mm (Transparent)	1	SW-410038
330006	Tornado Clutch Shoes	3	SW-330006	420010	Antenna Cup	1	SW-420010
330008A	SWORKz Tornado Fly Wheel Set (GM)	1	SW-330008A	420011	Fuel Tube	2	SW-420011
330008A	Tornado Fly Wheel Center Nut	1	SW-330008A	420026	S350/S350T Series Option Air Filter Extension Adapter	1	SW-420026
330008A	Fly Wheel Collect	1	SW-330008A	510080A	SWORKz 1/8 Off Road Formula Race Wing Decal	1	SW-228008BK
330015	Pin M2.2x9.9mm	6	SW-330015	510091	SWORKz Original Logo Sticker	1	SW-510091
330090	S350 Series Carbon Fiber Center Diff. Plate	1	SW-330090	540003	CABLE STRAPS FOR AIRFILTER	2	SW-540003
330100A	S350 Engine Mount (L) (HC)	1	SW-330100A	610004	Air Filter Outer Foam	1	SW-610004
330100A	S350 Engine Mount (R) (HC)	1	SW-330100A	610004	Air Filter Foam	1	SW-610004
330104	Brake Cam (S)	1	SW-330104	610019	S35-3 Series Servo Saver Spring Dusty Protect Sponge	1	SW-610019
330104	Brake Cam (L)	1	SW-330104	610020P	S35 Series Center Big Bore Diff. Paper Gasket (0.4T)	1	SW-610020P
330104	Brake Cam	1	SW-330104	610023P	S35-4 HET Diff. Paper Gasket (0.4T)	2	SW-610023P
330114A	S350 Sseries Servo Saver Post (HC)	1	SW-330114A	610025	SWORKz 1/8 Nitro Buggy High Density Air Filter Foam Set	1	SW-610025
330117A	S350 Series Knuckle Pivot Ball Washer(GM)	2	SW-330117A	115003A	SWORKz Tornado Clutch Spring II (1.0mm)	3	SW-115003A
330118A	S350 Series Knuckle Pivot Ball Nut(GM)	4	SW-330118A	115004A	Servo Saver Spring	1	SW-115004A
330119	Front Upper Arm Hinge Pin	2	SW-330119	115005	Rear Sway Bar 2.8mm	1	SW-115005
330121A	S350 Wheel Hub(HC)	4	SW-330121A	115006	Rear Sway Bar 2.6mm	1	SW-115006
330122A	S350 Wheel Nut (HC)	4	SW-330122A	115008A	Front Sway Bar 2.3mm	1	SW-115008A
330124	Pin M3.0x16.8mm	4	SW-330124	115011A	S35-GT Series Pipe Spring (L)	1	SW-115011A
330125	Rear Upper Sus. Arm Ball Stud	4	SW-330125	115019	Body Clip	2	SW-115019
338089	S35-T2/E Steering Linkage Turnbuckle M4x80mm	2	SW-338089	115035A	Front Sway Bar 2.2mm	1	SW-115035A
330134	Shock Ball Stud	12	SW-330134	115098	Brake Pad Spring	4	SW-115098
330136	Sway Bar Ball Stud	4	SW-330136	115168	S35 Series Black Competition Rear Shock Spring (L2-Dot)(86X1.6X10.75)	2	SWC-115168
330137	Clutch Bell 13T	1	SW-330137	115170	S35 Series Black Competition Front Shock Spring (S3-Dot)(70X1.6X8.5)	2	SWC-115170
330138B	S350 EVO Aluminum Shock Cap Stud (-1.3mm)	2	SW-330138B	116004R	Ball Bearing 6x10x3mm (Red Rubber Case)	4	SW-116004R
330140A	Pipe Holder(GM)	1	SW-330140A	116006R	Ball Bearing 8x16x5mm (Red Rubber Case)	14	SW-116006R
330140A	Pipe Spring	1	SW-330140A	116009	Ball Bearing M5x8x2.5 ZZ (4PC)	2	SW-116009
330155	Steering Servo Turnbuckle (M3x30mm)	2	SW-330155	116010R	Ball Bearing 5x10x4mm (Red Rubber Case)	2	SW-116010R
330156A	Adjuster Knob(GM)	4	SW-330156A	116019R	Ball Bearing 5x13x4mm (Red Rubber Case)	4	SW-116019R
330157A	Brake Adjuster Knob(GM)	2	SW-330157A	117003	Flange Ball Bearing 3x6x2.5mm	4	SW-117003
330243	SWORKz 3x16mm Shock Hex Screw Clockwise	2	SW-330243	118001-24	S35-T2/T2e Front Sway Bar 2.4mm	1	SW-118001-24
330243	SWORKz 3x16mm Shock Hex Screw Anti-Clockwise	2	SW-330243	118001-26	S35-T2/T2e Front Sway Bar 2.6mm	1	SW-118001-26
330252	S350 BX1/BR1 Steering Knuckle Pivot Ball Turnbuckle	4	SW-330252	118002-26	S35-T2/T2e Rear Sway Bar 2.6mm	1	SW-118002-26
330399B	S35-3 Series Aluminum Rear Chassis Brace Mount (GM)	1	SW-330399B	118002-28	S35-T2/T2e Rear Sway Bar 2.8mm	1	SW-118002-28
330458	S350T Rear Upper Arm Turnbuckle M5x72mm	2	SW-330458	101004	Washer 3.5X10X0.2mm	12	SW-101004
330557	S350 New BBS System Shock Seal Cap (GM)	4	SW-330557	101010A	M3 Countersunk Washer(GM)	4	SW-101010A
330560B	S35 New BBS System Shock Spring Adjust Nut (BK)	4	SW-330560B	101011	M2.6x6xT0.6mm	4	SW-101011
330562A	S350 New BBS System Shock Piston 1.3mmX6 Holes (BK)	2	SW-330562A	101013	3mm Spring Washer	4	SW-101013
330563A	S350 New BBS System Shock Piston 1.4mmX6 Holes (BK)	2	SW-330563A	101015	M5x8xT0.4mm	4	SW-101015
330580	S350 Competition Series Professional Brake Disc	2	SWC-330580	101016	M5x8xT0.8mm	1	SW-101016
330633	S350 BBS System +5.6mm Shock Body L (HD)	2	SW-330633	101018	SHIM 13x16x0.2mm	12	SW-101018
330634	S350 BBS System +5mm Shock Body S (HD)	2	SW-330634	101019	SHIM 6.0x10.0x0.2mm	1	SW-101019
330635	S350 New BBS System +5.5mm Shock Shaft (L)	2	SW-330635	101020A	S350 Sries 3mm Countersunk Washers (GM)	2	SW-101020A
330636	S350 New BBS System +1.3mm Shock Shaft (S)	2	SW-330636	101021	M3x8xT0.8mm	3	SW-101021
330647	S350 BBD Special Brake Cam	1	SWC-330647	101039	Steel Washer 5x12x0.3mm	6	SW-101039
330661A	S35-T/S35 Series Competition Center Drive Join (5mm set screw)	2	SW-330661A	103001	M3 Nut Lock	25	SW-103001
330767A	S35-3 Series Steel F-Center Dive Shaft (88mm)	1	SW-330767	103003A	Flange M3 Nut Lock (GM)	5	SW-103003A

Spare Part List

Part No.	Part Name	Q'ty in Use	Item No.	Item No.	Part Name
103004	M2.5mm Nut Lock	4	SW-103004	SW-228001	S35-4 Series Plastic Inserts Set (2Set)
103005	M4mm Nut Lock (BK)	1	SW-103005	SW-228002-1	S35-4 Series Plastic Rear Wheel Hub (R=L)(2PC)
104004	M3x3mm Set Screw	13	SW-104004	SW-228002-2	S35 Series Plastic Front Chassis Shorty Brace (1PC)
104005	M3x4mm Set Screw	4	SW-104005	SW-228003A	S35 Series Integrated Wing Mount Set 2.0
104010	M5x4mm Set Screw (Flat Bottom)	6	SW-104010	SW-228004A	S35-4 Series Plastic Side Guard Set with Stopper
104011	M4x4mm Set Screw (Flat Bottom)	1	SW-104011	SW-228006	S35 Series Shock End/Body Mount/Ball Ends Set (2Set)
105001	M3x8mm Cap Screw	1	SW-105001	SW-228008BK	SWORKz 1/8 Off Road Formula 2.0 Race Wing (BK)
105005	M3x12mm Cap Screw	6	SW-105005	SW-228010-F	S35-T2 Series Front Lower Arm (1PC)
105018	M2x6mm Cap Head Screw	1	SW-105018	SW-228010-R	S35-T2 Series Rear Lower Arm (1PC)
105013A	M3x25mm Cap Screw	4	SW-105013A	SW-228011	S35-T2 Series Front Upper Arm (1PC)
105007A	M4x8mm I-Head Screw Thin	4	SW-105007A	SW-2501097B	S35 Series Front Bumper (2PC)
105006A	M3x28mm Cap Screw full thread	2	SW-105006A	SW-2501115	S350 Rear Lower Arm Dusty Cover with Fuel Sprinkle Guard
106001	M3x8mm Hex Soket OH/TP Screw	3	SW-106001	SW-2501121C	S35/S350 Series Ball End Set with Shock Plastic Parts
106002	M3x10mm Hex Soket OH/TP Screw	18	SW-106002	SW-2501122C	S35/S350 Series Durable Setting Bellcrank Set (with Servo Horn)
106003	M3x16mm Hex Soket OH/TP Screw	8	SW-106003	SW-2501124	S350 Center Diff. Mount Set (2 Set)
106006	M3x20mm Hex Soket OH/TP Screw	1	SW-106006	SW-2501126A	S350/S350T Series Option Air Filter Extension Set
106007	M3x12mm Hex Soket OH/TP Screw (HT)	9	SW-106007	SW-2501529	S350 BX1/BR1 Rear Chassis Brace
106008	M3x12mm Hex Soket OH/TP Screw	4	SW-106008	SW-2502040-01	S350T Rear Chassis Brace
106009	M3x25mm Hex Soket OH/TP Screw	10	SW-106009	SW-2502040-02	S350T Body Mount with Fuel Tank Ring-pull
106013	M2.5x8mm 1.5mmHex Soket OH/ST Screw	6	SW-106013	SW-2503260	S35-3 Series Plastic Inserts Set
106015	M3x5mm Hex Soket OH/TP Screw	2	SW-106015	SW-2503261A	S35-3/GT Series Gear Box Set (Fit 5x13x4mm Ball Bearing)
106020	M2.5x5mm 1.5mmHex Soket OH/ST Screw	16	SW-106020	SW-2503262	S35-3 Nitro Buggy Radio Tray Set
106025	M2.5x8mm Hex Soket OH/TP Screw	5	SW-106025	SW-2503264A	S35-3 Series Front Steering Knuckle (Type 2.0)
106021A	S35 Series M4x10mm Hex Soket OH/TP Set Screw	4	SW-106021A	SW-2503270-03	S35-3 Series Front Steering Ball Ends (4PC)
108001	M3x12mm FH/ST HEX Screw	20	SW-108001	SW-200193	Antenna Tube
108003	M3x10mm FH/ST HEX Screw	21	SW-108003	SW-210018	Throttl Linkage Set
108005	M3x14mm FH/ST HEX Screw	2	SW-108005	SW-210043	S350 Professional Matel Brake Calipers 2.0 Set
108006	M3x8mm FH/ST HEX Screw	21	SW-108006	SW-210048X	S35-GT2/S35-T2 Series Tubed Floating Fuel Filter System Tank Set
108007	M3x6mm FH/ST HEX Screw	12	SW-108007	SW-210058	S350 series BBS Shock Seal Kit
108008	M3x35mm FH/ST HEX Screw	4	SW-108008	SW-210079A	S35-4 Plastic Center Big Bore HET Diff Case
108010	M4x10mm FH/ST HEX Screw	6	SW-108010	SW-210091	S35-3W Plastic Front/Rear Big Bore Diff Case
108011	M4x12mm FH/ST HEX Screw	1	SW-108011	SW-218018	S35-T2/e Series Universal Cross Drive Shaft Set 136.5mm (1PC)
108012	M4x16mm FH/ST HEX Screw	8	SW-108012	SW-250049ANC	S35-T2 Speed Rhinozero III Pre-Cut Nitro Body Shell (Clean/1.5mm)
108013	M4x8mm FH/ST HEX Screw	1	SW-108013	SW-328001	S35-3/4 Series HET Diff. Bevel Gear Set
108019	M2.6x6mm FH/ST HEX Screw	2	SW-108019	SW-330006	Tornado Clutch Shoes
108029	M2.0x4.6mm FH/ST HEX Screw (1.5mm HexHead)	4	SW-108029	SW-330008A	SWORKz Tornado Fly Wheel Set (GM)
				SW-330015	Pin M2.2x9.9mm
				SW-330090	S350 Series Carbon Fiber Center Diff. Plate
				SW-330100A	S350 Sseries Engine Mount Set (HC)
				SW-330104	Brake Cam Set
				SW-330114A	S350 Sseries Servo Saver Post (HC)
				SW-330117A	S350 Series Knuckle Pivot Ball Washer(GM)
				SW-330118A	S350 Series Knuckle Pivot Ball Nut(GM)
				SW-330119	Front Upper Arm Hinge Pin
				SW-330121A	S350 Wheel Hub (HC)
				SW-330122A	S350 Wheel Nut (HC)
				SW-330124	Pin M3.0x16.8mm
				SW-330126A	S350 EVO Steering Turnbuckle M4x40mm
				SW-330134	Shock Ball Stud 6mmxL6.7
				SW-330136	Sway Bar Ball Stud
				SW-330137	Clutch Bell 13T
				SW-330138B	S350 Series Aluminum Shock Cap Stud (-1.3mm)(2PC)
				SW-330140A	S350 SeriesPipe Holder(GM)
				SW-330155	Steering Servo Turnbuckle (M3x30mm)
				SW-330156A	S350 Series Adjuster Knob (Included Brake Adjuster Knob)(GM)
				SW-330157A	Brake Adjuster Knob(GM)
				SW-330243	SWORKz 3x18mm Shock Hex Screw Set (Anti-Clockwise)
				SW-330252	S350 BX1/BR1 Steering Knuckle Pivot Ball Turnbuckle
				SW-330399B	S35-3 Series Aluminum Rear Chassis Brace Mount (GM)
				SW-330458	S350T Rear Upper Arm Turnbuckle M5x72mm
				SW-330557	S350 New BBS System Shock Seal Cap (GM)
				SW-330560B	S35 New BBS System Shock Spring Adjust Nut (BK)
				SW-330562A	S35 Series BBS System Shock Piston 1.3mmX6 Holes (BK)(2PC)
				SW-330563A	S35 Series BBS System Shock Piston 1.4mmX6 Holes (BK)(2PC)
				SW-330633	S350 BBS System +5.6mm Shock Body L
				SW-330634	S350 BBS System +5mm Shock Body S
				SW-330635	S350 New BBS System +5.5mm Shock Shaft (L)
				SW-330636	S350 New BBS System +1.3mm Shock Shaft (S)
				SW-330661A	S35-T/S35 Series Competition Center Drive Join (5mm Set screw)
				SW-330663A	S35-3 Series Steel R-Center Drive Shaft (115mm)
				SW-330767A	S35-3 Series Steel F-Center Dive Shaft (88mm)
				SW-330777A	S35-4 Series Steering Linkage Ball Stud 7mm(L7)(4PC)
				SW-330782	S35-3 Series Rear Hub Carriers Hinge Pin
				SW-330822	S35-T Steel Center Rear Drive Shaft 165mm
				SW-338011	S35-3 series Pinion Gear Stopper (5x7x5.1mm)(4PC)
				SW-338014	S35-3W T-7075AL Rear Lower Fully Adjustable Toe-In Block(3 degree)
				SW-338045	S35-T Series HET System Pinion Gear 10T
				SW-338046	S35-T Series HET System Crown Gear 46T
				SW-338025	S35-4 HET Bevel Gear Shaft (2PC)
				SW-338027	S35-4 Front/Rear HET Diff. Outdrive (2PC)
				SW-338028	S35-4 Center HET Diff. Outdrive (2PC)
				SW-338041	S35-3/4 Series Center HET Spur Gear (48T)
				SW-338043	S35-3/4 Series Servo Saver Nut with Screw Fixed
				SW-338048	S35-4 Series Servo Saver Shaft(2PC)
				SW-338051	S35-4 Series T7 Aluminum Steering Knuckle Plate (R=L)
				SW-338052	S35-4 Series T7 Aluminum Setting Bellcrank Upper Part-A (with

Spare Part List

Item No.	Part Name	Item No.	Part Name
2Hole)		SW-115011A	S35-GT Series Pipe Spring (+10mm Longer)
SW-338053	S35-4 Series T7 Aluminum Steering Plate	SW-115019	Body Clip
SW-338056	S35-4 Series Lower Arm Hinge Pin (68.5mm)(2PC)	SW-115098	Brake Pad Spring
SW-338057	S35-4 Series T7 Aluminum Front Upper Arm Holder	SWC-115168	S35 Series Black Competition Rear Shock Spring (L2-Dot)(86X1.6X10.75)
SW-338058	S35-4 Series T7 Aluminum Front Lower Arm Plate (FF)	SWC-115170	S35 Series Black Competition Front Shock Spring (S3-Dot)(70X1.6X8.5)
SW-338059	S35-4 Series T7 Aluminum Front Lower Arm Holder (FR)	SW-116004R	Ball Bearing 6x10x3mm (Red Rubber Case)(4PC)
SW-338067	S35-4 Series Emulsion/Bladder 2 Ways Syatem Shock Cap (2PC)	SW-116006R	Ball Bearing 8x16x5mm (Red Rubber Case)(10PC)
SW-338068	S35-4 Series T7 Aluminum Shock Stud (L)(2PC)	SW-116009	Ball Bearing M5x8x2.5 ZZ (4PC)
SW-338070B	S35 Series Rear Upper Sus. Arm Ball Stud (7.0mm Hex)	SW-116010R	Ball Bearing 5x10x4mm (Red Rubber Case)(4PC)
SW-338085	S35-T2/E T7075 Aluminum Front Shock Tower	SW-116019R	Ball Bearing 5x13x4mm (Red Rubber Case)(4PC)
SW-338086	S35-T2/E T7075 Aluminum Rear Shock Tower	SW-117003	Flange Ball Bearing 3x6x2.5mm (2PC)
SW-338087	S35-T2 Nitro T7075 Aluminum Lightened Main Chassis	SW-118001-24	S35-T2/T2e Front Sway Bar 2.4mm
SW-338089	S35-T2/e Steering Linkage Turnbuckle M4x80mm	SW-118001-26	S35-T2/T2e Front Sway Bar 2.6mm
SW-338114	S35-4 Series T7075 Aluminum Intensity Rear Front Lower Suspension Plate	SW-118002-26	S35-T2/T2e Rear Sway Bar 2.6mm
SW-340016	S35-4 Series Pro-composite Carbon Rear Wheel Hub Adjust Plate (R=L)(2PC)	SW-118002-28	S35-T2/T2e Rear Sway Bar 2.8mm
SW-340017	S35-4 Series Pro-composite Carbon Steering Bellcrank Plate		
SW-340028-10	S35-T2/e Pro-composite Carbon Front Upper Arm Cover (1.0mm)(2PC)		
SWC-330580	S350 Competition Series Professional Brake Disc		
SWC-330647	S350 BBD Special Brake Cam		
SW-400002	O-ring S5 4.8X1.5		
SW-400005	Shock Spring Adjust Nut O-Ring		
SW-400009	Shock Boot (L)		
SW-400010	Shock Boot (S)		
SW-400019	S350 New BBS System Shock Spring Adjust Nut O-Ring (4PC)		
SW-400020	S350 New BBS System Shock Seal O-Ring (4PC)		
SW-400023	S35-4 Series BBS System Seal O-Ring for Emulsion Shock Cap (4PC)		
SW-400022A-S	S35 Series BBS System Pro Shock Bladder (Soft)(8PC)		
SW-410038	Super Silicone Tube 2455x30mm (Transparent)		
SW-420010	Antenna Cup		
SW-420026	S350/S350T Series Option Air Filter Extension Adapter		
SW-510091	SWORKz Original Logo Sticker (2PC)		
SW-540003	SWORKz Cable Straps for 1/8 Buggy Airfilter (10PC)		
SW-610004	Air Filter Foam Set		
SW-610019	S35-3 Series Servo Saver Spring Dusty Protect Sponge (2PC)		
SW-610020P	S35 Series Center Big Bore Diff. Paper Gasket (0.4T)(3PC)		
SW-610023P	S35-4 HET Diff. Paper Gasket (0.4T)(3PC)		
SW-610025	SWORKz 1/8 Nitro Buggy High Density Air Filter Foam Set (12 Sets)		
SW-101004	Washer 3.5X10X0.2mm		
SW-101010A	M3 Countersunk Washer (GM)		
SW-101011	M2.6x6xT0.6mm		
SW-101013	3mm Spring Washer		
SW-101015	M5x8xT0.4mm		
SW-101016	M5x8xT0.8mm		
SW-101018	SHIM 13x16x0.2mm		
SW-101019	SHIM 6.0x10.0x0.2mm		
SW-101020A	S350 Sries 3mm Countersunk Washers (GM)		
SW-101021	M3x8xT0.8mm		
SW-101039	SWORKz HET Diff Steel Washer 5x12x0.3mm (10PC)		
SW-103001	M3 Nut Lock		
SW-103003A	Flange M3 Nut Lock (GM)		
SW-103004	M2.5mm Nut Lock		
SW-104004	M3x3mm Set Screw		
SW-104005	M3x4mm Set Screw		
SW-104010	M5x4mm Set Screw (Flat Bottom)		
SW-104011	M4x4mm Set Screw (Flat Bottom)		
SW-105001	M3x8mm Cap Screw		
SW-105005	M3x12mm Cap Screw		
SW-105006A	M3x28mm Cap Screw full thread		
SW-105007A	M4x8mm I-Head Screw Thin		
SW-105013A	M3x25mm Cap Screw		
SW-105018	M2x6mm Cap Head Screw		
SW-106001	M3x8mm Hex Soket OH/TP Screw		
SW-106002	M3x10mm Hex Soket OH/TP Screw		
SW-106003	M3x16mm Hex Soket OH/TP Screw		
SW-106006	M3x20mm Hex Soket OH/TP Screw		
SW-106007	M3x12mm Hex Soket OH/TP Screw (HT)		
SW-106008	M3x12mm Hex Soket OH/TP Screw		
SW-106009	M3x25mm Hex Soket OH/TP Screw		
SW-106013	M2.5x8mm 1.5mmHex Soket OH/ST Screw		
SW-106015	M3x5mm Hex Soket OH/TP Screw		
SW-106020	M2.5x5mm 1.5mmHex Soket OH/ST Screw		
SW-106021A	S35 Series M4x10mm Hex Soket OH/TP Set Screw		
SW-108001	M3x12mm FH/ST HEX Screw		
SW-108003	M3x10mm FH/ST HEX Screw		
SW-108005	M3x14mm FH/ST HEX Screw		
SW-108006	M3x8mm FH/ST HEX Screw		
SW-108007	M3x6mm FH/ST HEX Screw		
SW-108008	M3x35mm FH/ST HEX Screw		
SW-108010	M4x10mm FH/ST HEX Screw		
SW-108011	M4x12mm FH/ST HEX Screw		
SW-108012	M4x16mm FH/ST HEX Screw		
SW-108013	M4x8mm FH/ST HEX Screw		
SW-108019	M2.6x6mm FH/ST HEX Screw		
SW-108029	M2.0x4.6mm FH/ST HEX Screw (1.5mm HexHead)		
SW-115003A	SWORKz Tornado Clutch Spring II (1.0mm)		
SW-115004A	Servo Saver Spring		

Option Part List

Item No.	Part Name	Item No.	Part Name
SW-2501114-4	S35-3/S350 Nitro Series Center Brake Disk Holder	SWC-115165	S35 Series Black Competition Front Shock Spring (M2-Dot)(75X1.6X9.25)
SW-2501126	Air Filter Set	SWC-115166	S35 Series Black Competition Rear Shock Spring (L4-Dot)(86X1.6X10.25)
SW-2501529H	S35/S350 Series Hard Plastic Chassis Brace Set	SWC-115167	S35 Series Black Competition Rear Shock Spring (L3-Dot)(86X1.6X10.5)
SW-2503260FO	S353 Series Colorful Plastic Inserts Set (FO)	SWC-115169	S35 Series Black Competition Front Shock Spring (S4-Dot)(70X1.6X8.25)
SW-2503260FY	S353 Series Colorful Plastic Inserts Set (FY)	SWC-115171	S35 Series Black Competition Front Shock Spring (S2-Dot)(70X1.6X8.75)
SW-2503260LB	S353 Series Colorful Plastic Inserts Set (SB)(2 Set)	SWC-115190	S35 Series Competition Black Line Rear Shock Spring (RM4-Dot)(80X1.6X9.75)
SW-210079AH	S35-4 Plastic Center Big Bore HET Diff Case (Hard)	SWC-115191	S35 Series Competition Black Line Rear Shock Spring (RM3-Dot)(80X1.6X10.0)
SW-210091H	S35-4 Plastic Front/Rear Big Bore HET Diff Case (Hard)	SWC-115192	S35 Series Competition Black Line Rear Shock Spring (RM2-Dot)(80X1.6X10.25)
SW-218005	S35-3/4 Series HET Center Big Bore Diff. Set (47T)	SW-118001-25	S35-T2/T2e Front Sway Bar 2.5mm
SW-218014	S35-T/S35-TE Series HET Diff. Combo Set	SW-118001-27	S35-T2/T2e Front Sway Bar 2.7mm
SW-228008WH	SWORKz 1/8 Off Road Formula 2.0 Race Wing (WH)	SW-118002-27	S35-T2/T2e Rear Sway Bar 2.7mm
SW-228013BK	SWORKz 1/8 Off Road Pro-Speed 2.0 Race Wing (BK)(Pre-Holes)	SW-118002-30	S35-T2/T2e Rear Sway Bar 3.0mm
SW-228013WH	SWORKz 1/8 Off Road Pro-Speed 2.0 Race Wing (WH)(Pre-Holes)		
SW-228013FY	SWORKz 1/8 Off Road Pro-Speed 2.0 Race Wing (FY)(Pre-Holes)		
SW-228001RD	S35-4 Series Colorful Plastic Inserts Set (Red)		
SW-300049	SWORKz S35-3/S350 Series Rear Stainless Chassis End Protection (2PC)		
SW-330006A	Tornado Clutch Shoes (2Set)		
SW-330115	Steering Knuckle Pivot Ball Turnbuckle		
SW-330116	14mm Knuckle Pivot Ball		
SW-330125A	S350 Series Aluminum Rear Upper Sus. Arm Ball Stud (4PC)		
SW-330134A	S350 Series Aluminum Shock Ball Stud (4PC)		
SW-330136A	S350 Series Aluminum Sway Bar Ball Stud (4PC)		
SW-330168A	S35-3 Series Rear Chassis Blance wight 15g (2PC)		
SW-330202	S-WORKz Turbo Tornado Fly Wheel Set		
SW-330398A	SWORKz S350 Series Pro Wheel Nut (GM)		
SW-330420	S350 Series Knuckle Pivot Ball Balance Nut (5.5g) (2PC)		
SW-330424	S350 Series Aluminum Wing Holder (RED)		
SW-330424B	S350 Series Aluminum Wing Holder (BK)		
SW-330424G	S350 Series Aluminum Wing Holder (GM)		
SW-330505A	S35 Series Lightened Wheel Hub for 8mm Axil (L6.5mm)		
SW-330506A	S35 Series Lightened Wheel Hub for 8mm Axil (L5.0mm)		
SW-330564A	S35 Series BBS System Shock Piston 1.5mmX6 Holes (BK)		
SW-330565	S350 BBS System Shock Piston 1.3mmX8 Oblique Holes (2PC)		
SW-330566	S350 BBS System Shock Piston 1.2mmX8 Oblique Holes (2PC)		
SW-330568	S350 Buggy Series Aluminum Center Diff. Mount		
SW-330767	S35-3 Series T-7075 Aluminum F-Center Dive Shaft (88mm)		
SW-330777B	S35-4 Series Aluminum Steering Linkage Ball Stud 7mm (L7)(4PC)		
SW-338070A	S35 Series Rear Upper Arm Aluminum Ball Stud (2PC)		
SW-338078-25	SWORKz Uni-Design 2-Way System Aluminum Steering Servo Horn 25T		
SW-338078-23	SWORKz Uni-Design 2-Way System Aluminum Steering Servo Horn 23T		
SW-338079-25	SWORKz Uni-Design Aluminum Throttle Servo Horn 25T		
SW-338079-23	SWORKz Uni-Design Aluminum Throttle Servo Horn 23T		
SW-338029-16	S35-4 Series High Density Clutch Bell 16T		
SW-338030-59	S35-4 Series High Density Spur Gear for Big Bore Diff. Case (59T)		
SW-338030-60	S35-4 Series High Density Spur Gear for Big Bore Diff. Case (60T)		
SW-338122-R	S35/S350/Apollo Series Lightened Steering Knuckle Pivot Ball Turnbuckle (Clockwise)(2PC)		
SW-338122-L	S35/S350/Apollo Series Lightened Steering Knuckle Pivot Ball Turnbuckle (Anti-Clockwise)(2PC)		
SW-340029-15	S35-T2/e Pro-composite Carbon Front Lower Arm Cover (1.5mm)(2PC)		
SW-340030-15	S35-T2/e Pro-composite Carbon Rear Lower Arm Cover (1.5mm)(2PC)		
SW-400022A-M	S35 Series BBS System Pro Shock Bladder (Medium)(8PC)		
SW-400024S	S35 Series BBS System Hex-Cell Shock Bladder(Soft)(4PC)		
SW-400024M	S35 Series BBS System Hex-Cell Shock Bladder(Medium)(4PC)		
SW-410023	Air Filter Adapter		
SW-610025A	SWORKz 1/8 Nitro Buggy High Density Air Filter Foam Set (6 Sets)		
SW-610025C	SWORKz 1/8 Nitro Buggy High Density Air Filter Foam Set with Air Filter Oil		
SWC-115107	S350 Competition Shock Spring A-2 (75X1.4X7.25)(Red)		
SWC-115109	S350 Competition Shock Spring B-2 (90X1.4X8.5)(Pink)		
SWC-115110	S350 Competition Shock Spring C-1 (75X1.5X7.75)(SkyBlue)		
SWC-115118	S350 Competition Shock Spring E-3 (90X1.5X8.5)(Blue)		
SW-115026A	SWORKz Tornado Clutch Spring II (1.1mm)(GR)		
SW-115027A	SWORKz Tornado Clutch Spring II (1.2mm)(GD)		
SW-115077A	SWORKz Tornado Clutch Spring II (0.9mm)(BK)		
SW-116006A	High Performance Rubber Cover Ball Bearing 8x16x5mm (10PC)		
SW-116010B	High Performance Ball Bearing 5x10x4mm (coffee)(4PC)		
SW-116019C	SWORKz High Performance 5x13x4mm Ball Bearing (Rubber Case)(4PC)		
SWC-116006C	SWORKz Competition 8x16x5mm Ball Bearing (Metal Case)(6PC)		
SWC-116010C	SWORKz Competition 5x10x4mm Ball Bearing (Metal Case)(6PC)		
SWC-116019A	SWORKz Competition 5x13x4mm Ball Bearing (Metal Case)(4PC)		
SWC-116019B	SWORKz Competition 5x13x4mm Ball Bearing (Metal Case/Japan)(4PC)		
SWC-210088	S35-3 Nitro Series Pro-composite Carbon One Unit Radio Tray Set		
SWC-338006	SWORKz Tornado Hi-Performance Lightened Clutch Bell (13T)		
SW-338036	SWORKz 1/8 Nitro Series Pipe Spring Lock (1 Set)		
SW-338075	S35-4 Series T7 Aluminum Rear Wheel Hub (R=L)(2PC)		
SWC-218020-6LD	S35 Series 1-Unit-Fit Aluminum Engine Mount Set (6 Degree Lay-Down)		
SWC-218020-4LD	S35 Series 1-Unit-Fit Aluminum Engine Mount Set (4 Degree Lay-Down)		
SWC-338095	S35 Series 1-Unit-Fit Aluminum Engine Mount (6 Degree Lay-Down)		
SWC-338096	S35 Series 1-Unit-Fit Aluminum Engine Mount (Upper)(2PC)		
SWC-338097	S35 Series 1-Unit-Fit Aluminum Engine Mount (4 Degree Lay-Down)		
SWC-115163	S35 Series Black Competition Front Shock Spring (M4-Dot)(75X1.6X8.75)		
SWC-115164	S35 Series Black Competition Front Shock Spring (M3-Dot)(75X1.6X9.0)		

Exploded View

Shock Absorbers

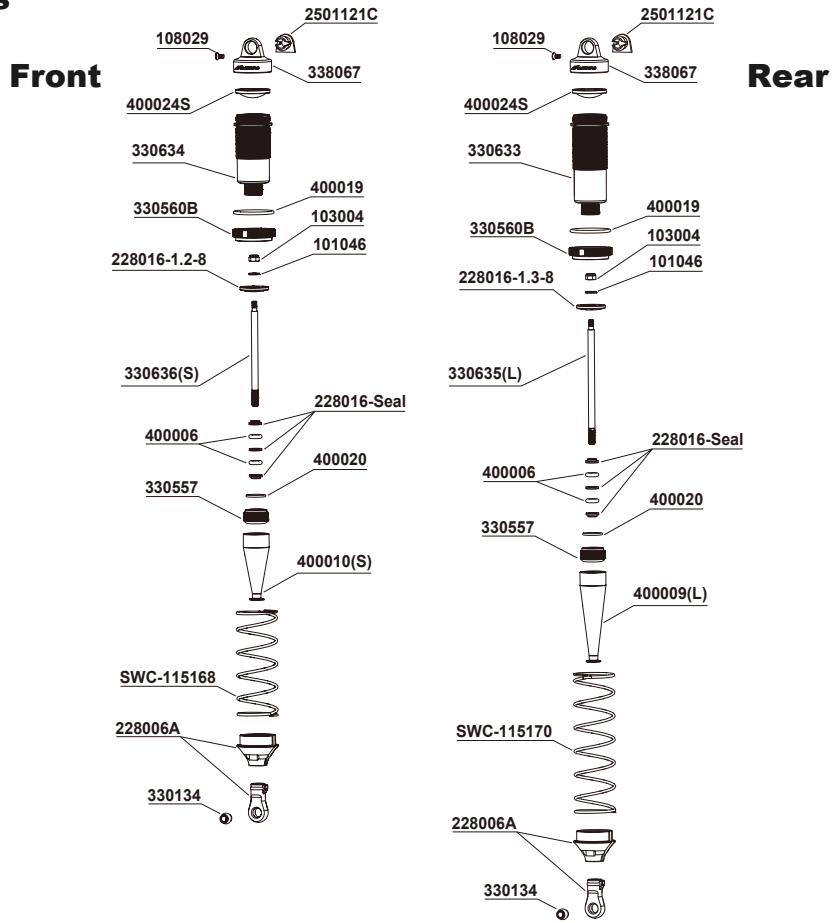

Differential

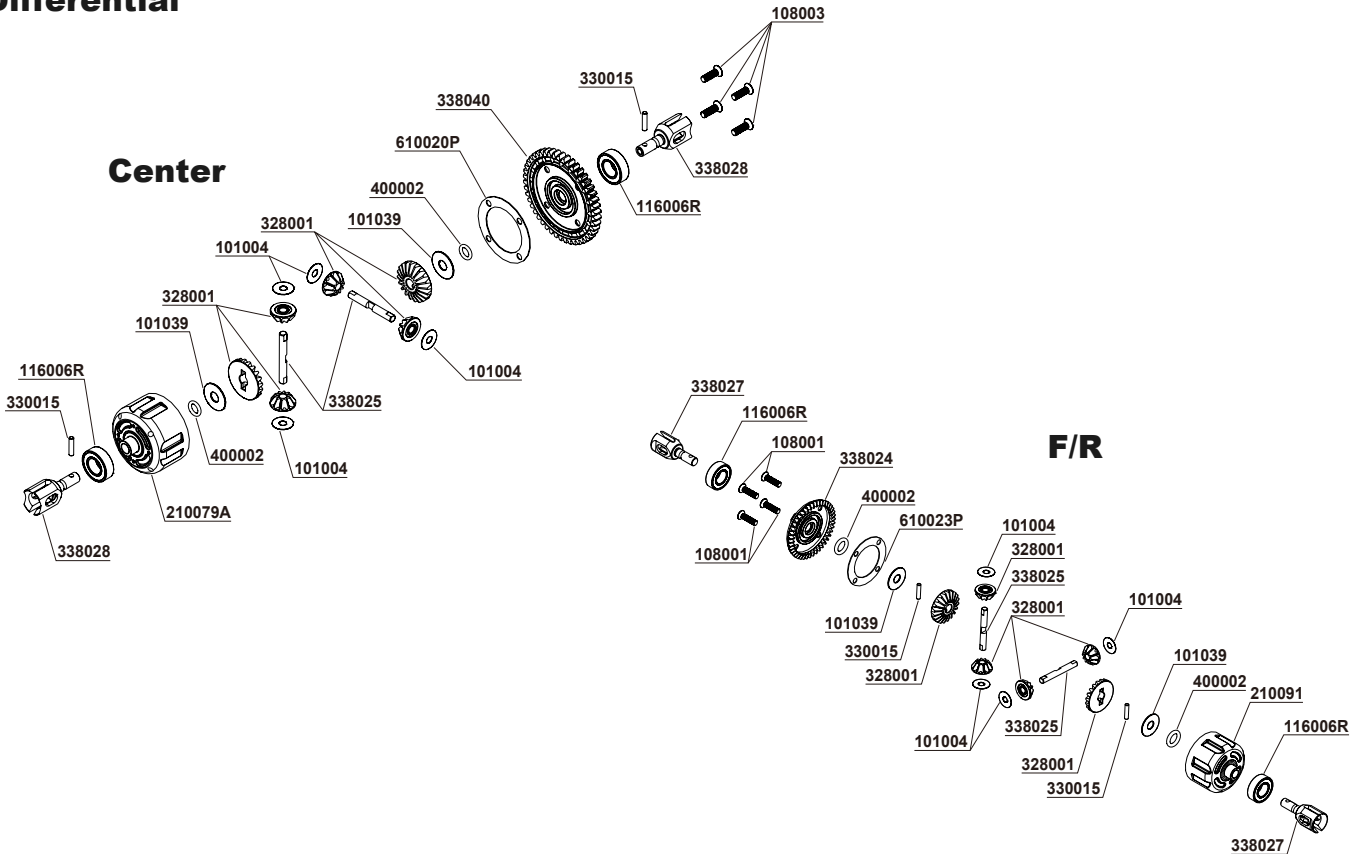

Front Suspension

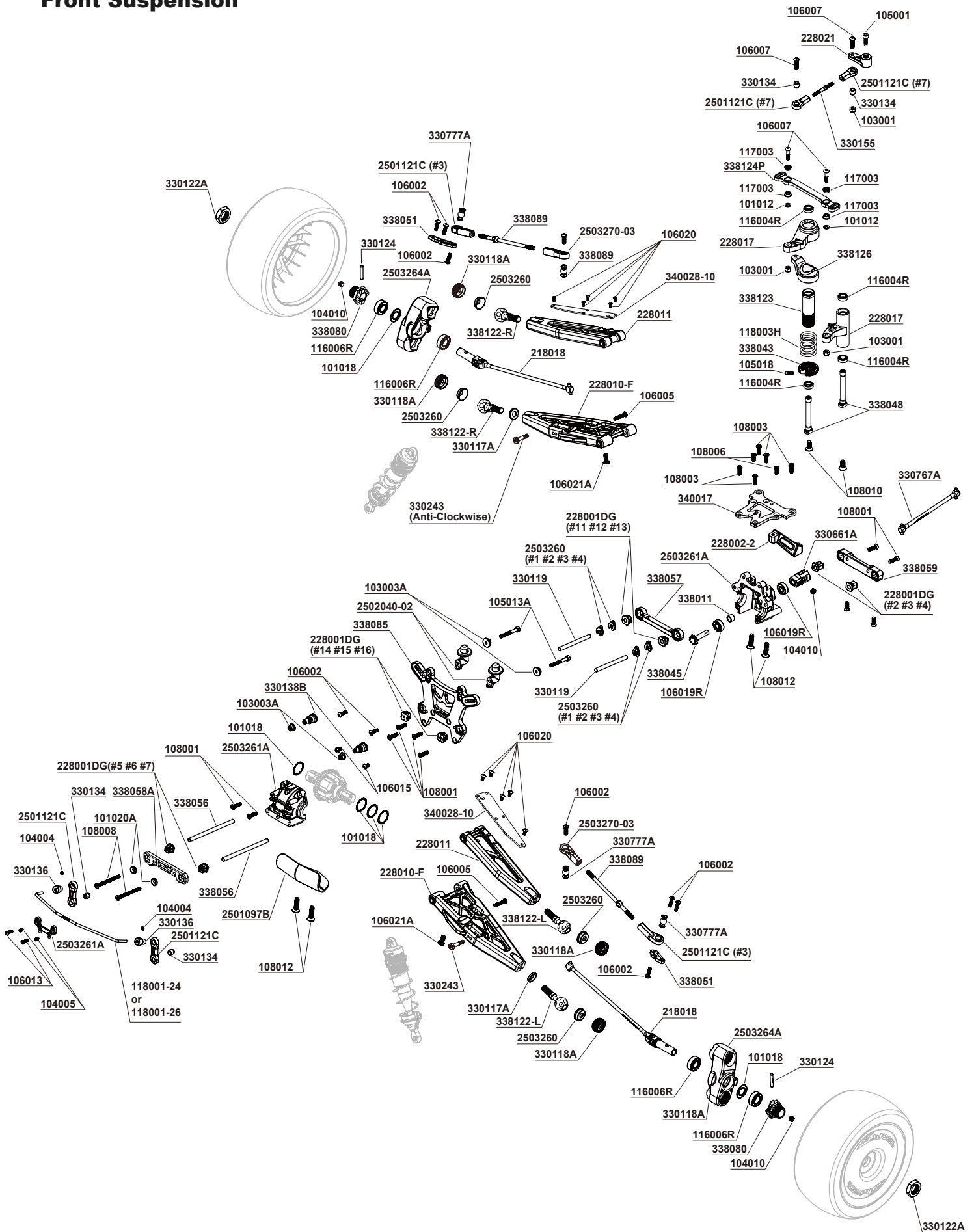

Exploded View

Center Transmission

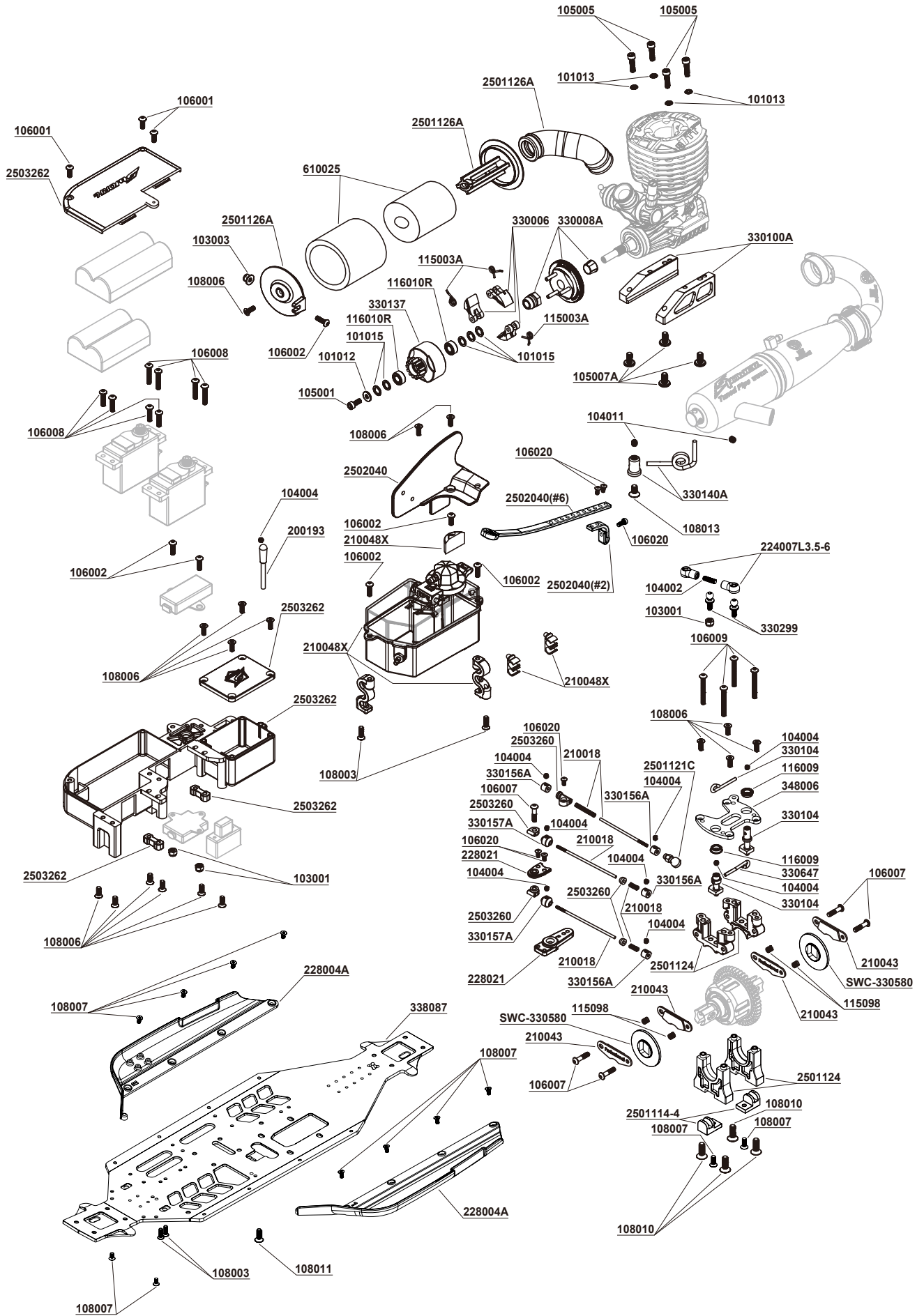

Rear Suspension

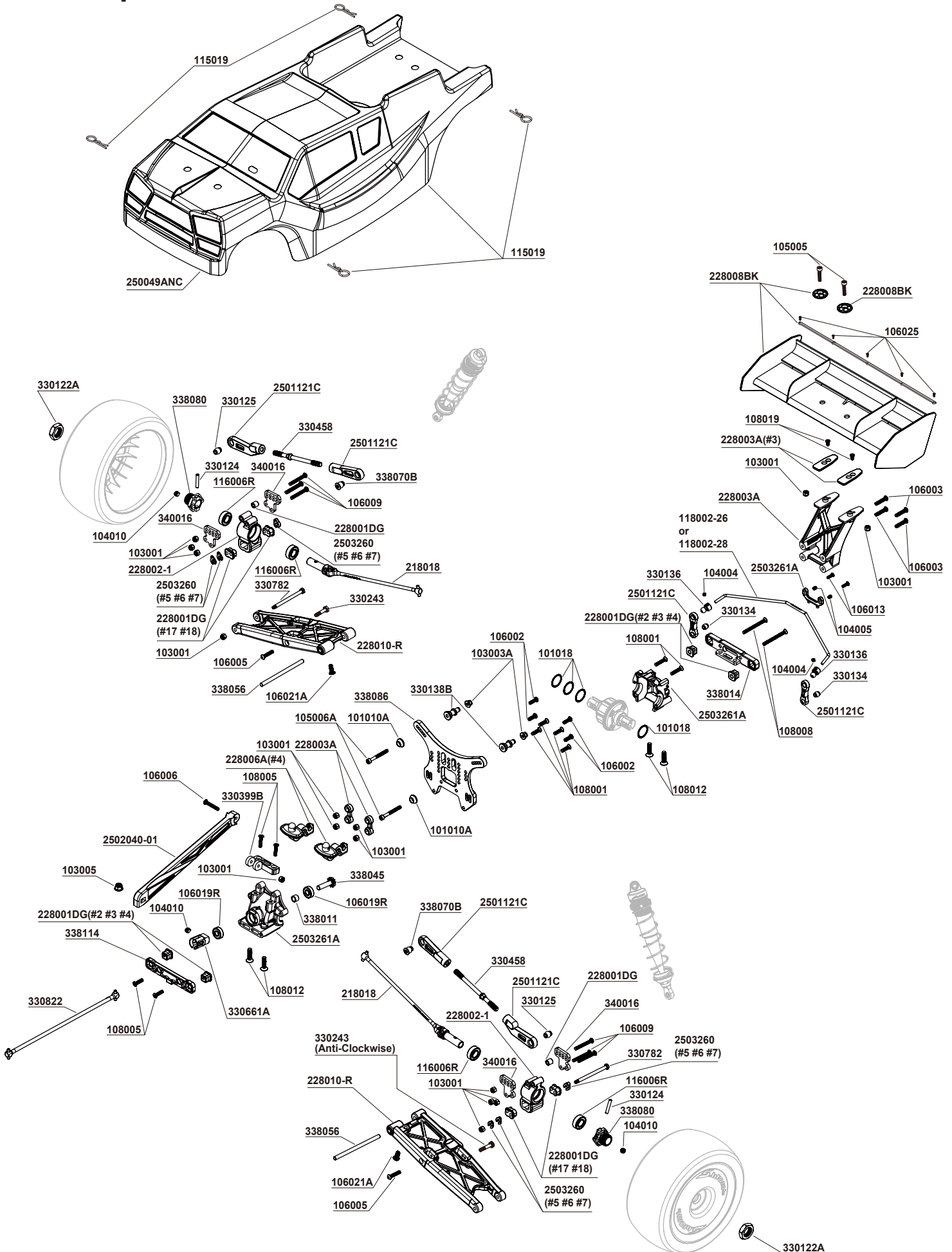

S35-F2EVO

1/8 OffRoad Nitro Power Pro Truggy



SPEEDMASTER HOBBY CO., LTD.

TEL: +886-3-538-7638

FAX: +886-3-538-7328

No.42, Ruiguang St., Xiangshan Dist.,
Hsinchu City 300, Taiwan (R.O.C.)

www.sworkz.com